

**Wentworth Hall
Library
Expansion**
Washington Street
Islington, MA

OWNER

mckay
architects

35 Bryant Street
Dorham, MA 02026
ph: 781.326.5400
www.mckayarchitects.net

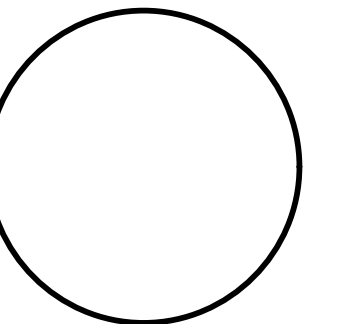

REV # | DATE | ISSUANCE

REV #	DATE	ISSUANCE

OWNERSHIP & USE OF DOCUMENTS

These drawings and specifications are the property and copyright of McKay Architects and shall not be used in whole or in part, or shall be assigned to a third party without the express written permission of McKay Architects.
Contractor to verify all information and dimensions in the field prior to start of construction and is to notify McKay Architects of any discrepancies.

**First Floor
Reflected Ceiling
Plan**

JOB NO	
DATE	1.21.2020
DWG BY	RJM
CKD BY	MLM
SCALE	

A-1.5

1/4" = 1'-0"

PRELIMINARY FIXTURE SCHEDULE	
⊕ _{P1}	PENDANT LIGHT 1
⊕ _{P2}	PENDANT LIGHT 2
⊕ _{P3}	PENDANT LIGHT 3
⊕ _A	
⊕ _B	WORK LIGHT
⊕ _C	TRACK LIGHT
○ _{R1}	RECESSED LIGHT 1
□ ₁	2'-0" X 2'-0" FLORESCENT LIGHT
EXIT	EXIT SIGN
⊕ _{EM}	EMERGENCY LIGHTS
⊕ _{EF}	EXHAUST FAN 60 CFM W/ 4" DUCT TO WALL CAP
NOTE: FINAL LIGHT FIXTURE LOCATIONS ARE TO BE COORDINATED W/ OWNER / ARCHITECT PRIOR TO INSTALLATION.	

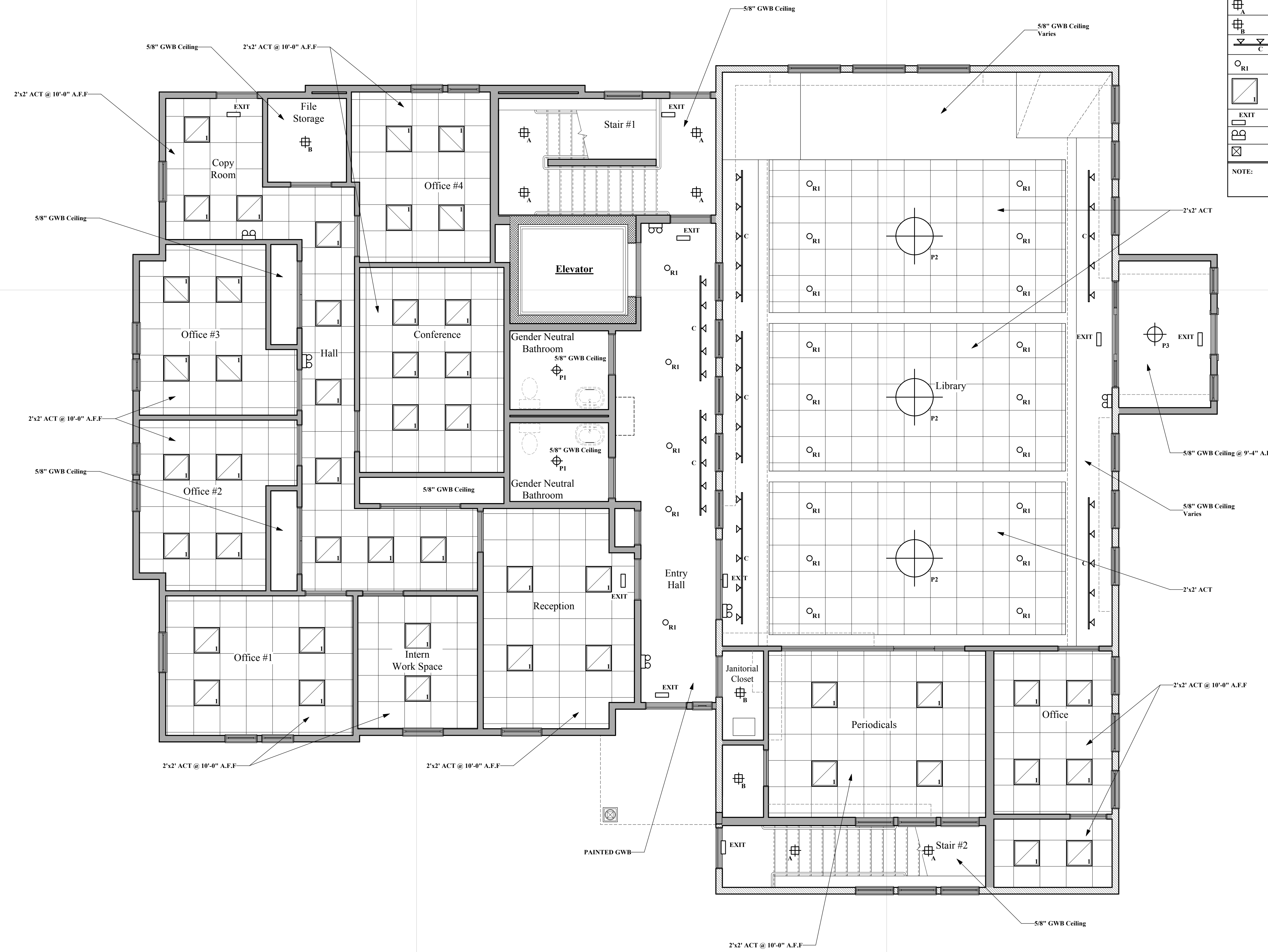

1 First Floor Reflected Ceiling Plan
A-1.5 1/4" = 1'-0"

REFER TO BUILDING SECTIONS FOR ADDITIONAL
INFORMATION ON CEILING HEIGHTS

**Wentworth Hall
Library
Expansion**

Washington Street
Islington, MA

OWNER

architects
mckay

35 Bryant Street
Dorham, MA 02026
ph: 781.326.5400
www.mckayarchitects.net

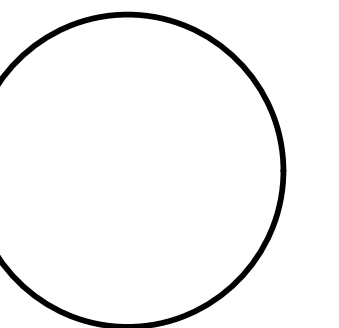

REV #	DATE	ISSUANCE

OWNERSHIP & USE OF DOCUMENTS

These drawings and specifications are the property and copyright of McKay Architects and shall not be used in whole or in part, or shall be assigned to a third party without the express written permission of McKay Architects.
Contractor to verify all information and dimensions in the field prior to start of construction and is to notify McKay Architects of any discrepancies.

**Basement Floor
Flooring Plan**

JOB NO	
DATE	1.21.2020
DWG BY	RJM
CKD BY	MLM
SCALE	1/4" = 1'-0"

A-1.6

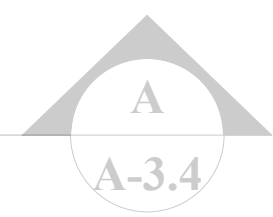
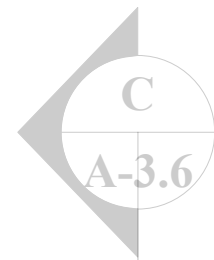

SEALED CONCRETE

Elevator
Machine Room

Stair #1

Elevator

CONCRETE SLAB
NO FINISH

Tech. Closet

12" X 12" VCT AND 4" VINYL
BASE

Stair #2

12" X 12" VCT AND 4" VINYL
BASE
CARPET TREADS AND RISERS

12" X 12" VCT AND 4" VINYL
BASE
CARPET TREADS AND RISERS

1 Basement Floor Flooring Plan

A-1.4 1/4" = 1'-0"

**Wentworth Hall
Library
Expansion**

**Washington Street
Islington, MA**

OWNER

mckay
architects

35 Bryant Street
Dorham, MA 02026
ph: 781.326.5400
www.mckayarchitects.net

GENERAL NOTE:

ALL TRIM (INCLUDING WATER TABLES, SILLS, CORNER BOARDS, RAKES, FASCIAS, SOFFITS) TO BE CELLULAR PVC BOARD.

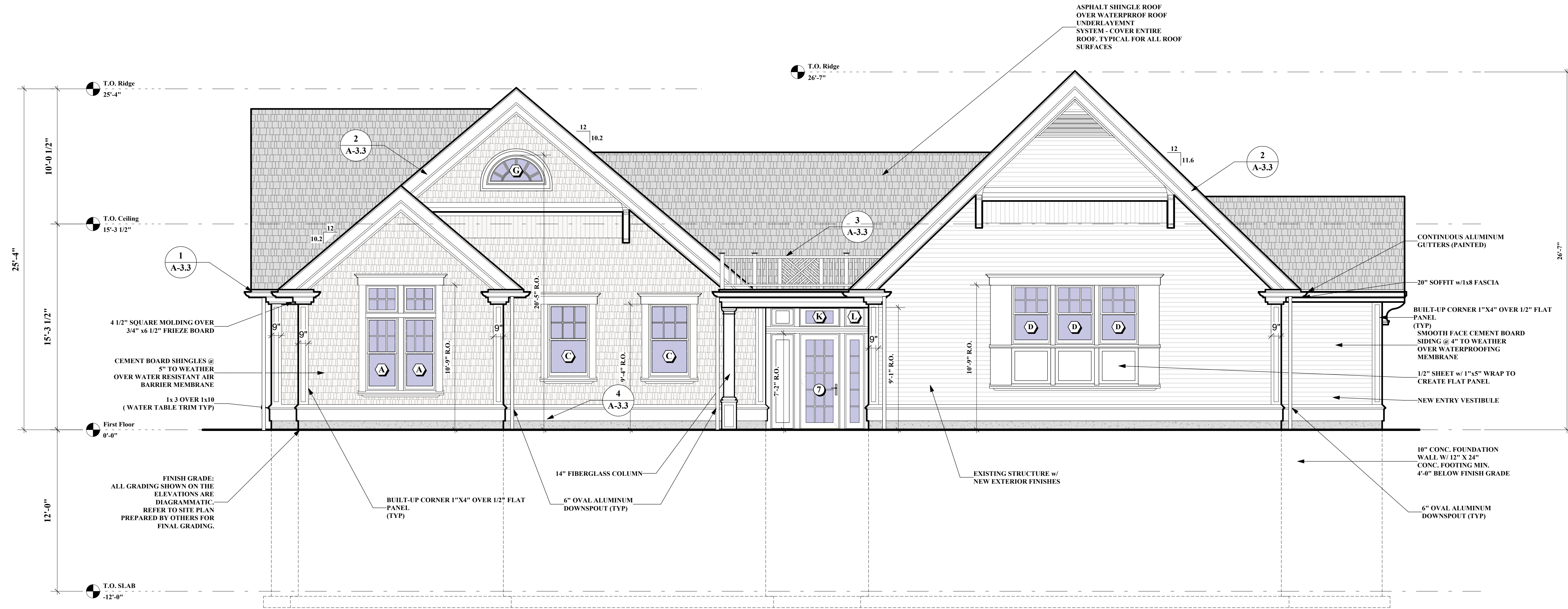

1 Proposed Left Side Elevation
A-2.2 1/4" = 1'-0"

REV #	DATE	ISSUANCE

OWNERSHIP & USE OF DOCUMENTS
These drawings and specifications are the property and copyright of McKay Architects and shall not be used in whole or in part, or shall be assigned to a third party without the express written permission of McKay Architects.
Contractor to verify all information and dimensions in the field prior to start of construction and is to notify McKay Architects of any discrepancies.

**Proposed Left
(South)
Side Elevation**

JOB NO	
DATE	1.21.2020
DWG BY	RJM
CKD BY	MLM
SCALE	1/4" = 1'-0"

A-2.2

**Wentworth Hall
Library
Expansion**

**Washington Street
Islington, MA**

OWNER

mckay
architects

35 Bryant Street
Dorham, MA 02026
ph: 781.326.5400
www.mckayarchitects.net

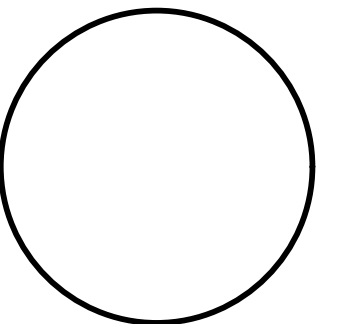

REV # DATE ISSUANCE

REV #	DATE	ISSUANCE

OWNERSHIP & USE OF DOCUMENTS

These drawings and specifications are the property and copyright of McKay Architects and shall not be used in whole or in part, or shall be assigned to a third party without the express written permission of McKay Architects.
Contractor to verify all information and dimensions in the field prior to start of construction and is to notify McKay Architects of any discrepancies.

**Proposed Rear
(West)
Elevation**

JOB NO	
DATE	1.21.2020
DWG BY	RJM
CKD BY	MLM
SCALE	

A-2.3

1/4" = 1'-0"

GENERAL NOTE:

ALL TRIM (INCLUDING WATER TABLES, SILLS, CORNER BOARDS, RAKES, FASCIAS, SOFFITS) TO BE CELLULAR PVC BOARD.

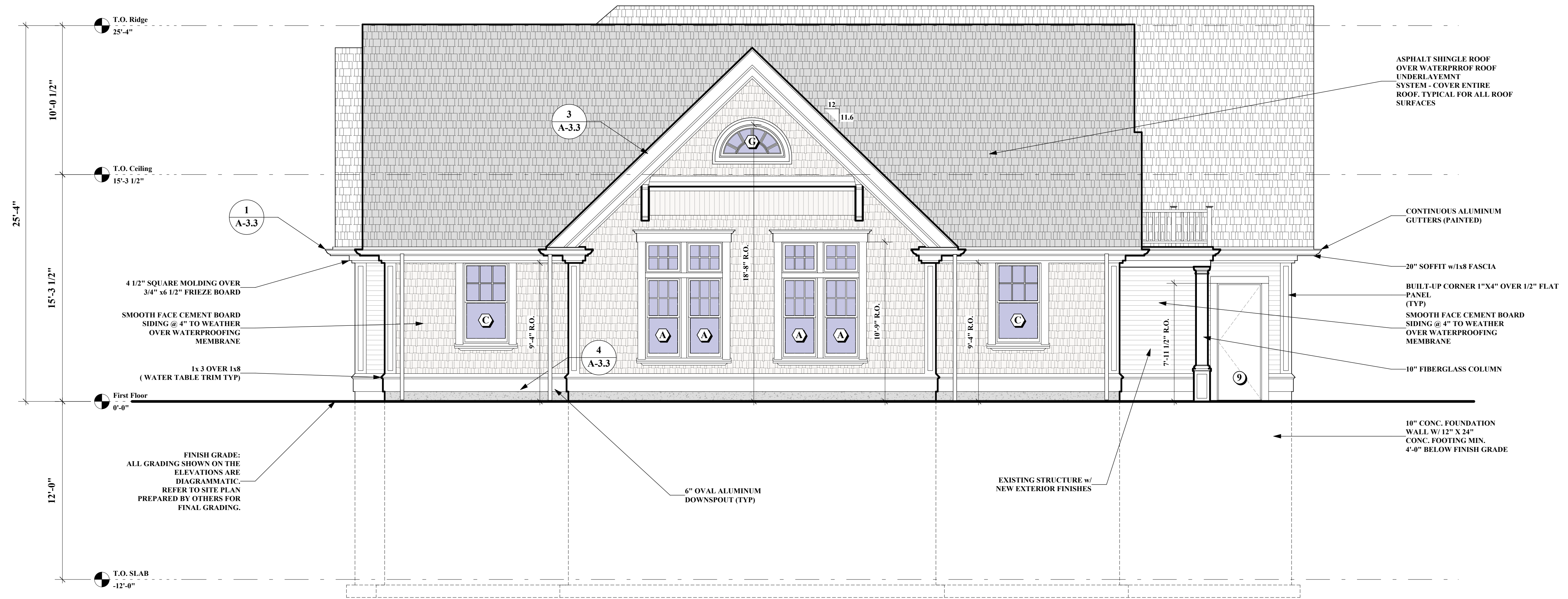

1 Proposed Rear Elevation
A-2.3 1/4" = 1'-0"

**Wentworth Hall
Library
Expansion**

**Washington Street
Islington, MA**

OWNER

mckay
architects

35 Bryant Street
Dorham, MA 02026
ph: 781.326.5400
www.mckayarchitects.net

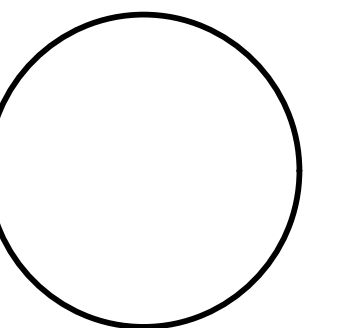

REV # DATE ISSUANCE

REV #	DATE	ISSUANCE

OWNERSHIP & USE OF DOCUMENTS

These drawings and specifications are the property and copyright of McKay Architects and shall not be used in whole or in part, or shall be assigned to a third party without the express written permission of McKay Architects.
Contractor to verify all information and dimensions in the field prior to start of construction and is to notify McKay Architects of any discrepancies.

**Proposed Right
(North)
Side Elevation**

JOB NO	
DATE	1.21.2020
DWG BY	RJM
CKD BY	MLM
SCALE	1/4" = 1'-0"

A-2.4

GENERAL NOTE:

ALL TRIM (INCLUDING WATER TABLES, SILLS, CORNER BOARDS, RAKES, FASCIAS, SOFFITS) TO BE CELLULAR PVC BOARD.

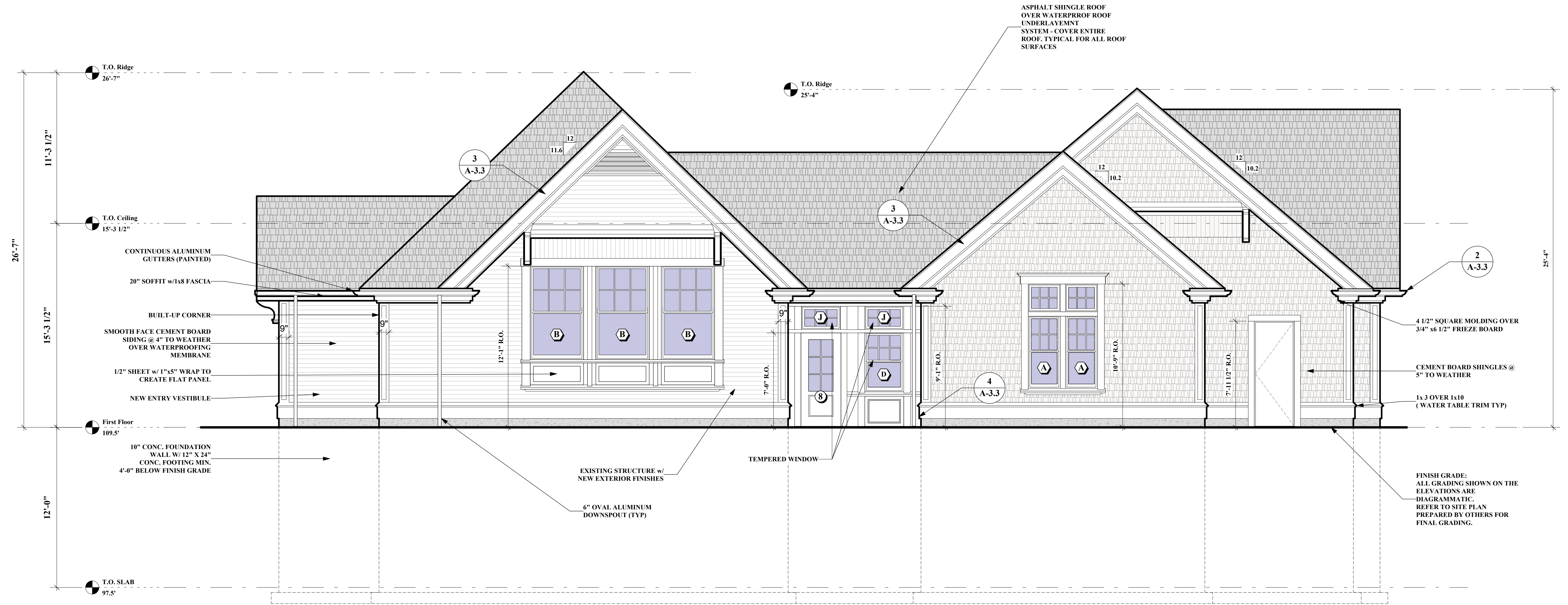

1 Proposed Right Side Elevation

A-2.4 1/4" = 1'-0"

**Wentworth Hall
Library
Expansion**

**Washington Street
Islington, MA**

OWNER

architects
mckay

35 Bryant Street
Dorham, MA 02026
ph. 781.326.5400
www.mckayarchitects.net

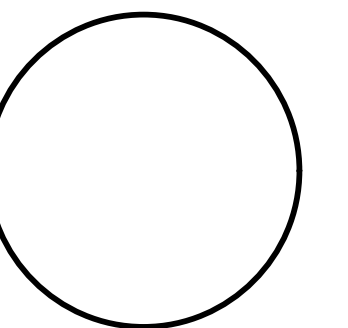

REV # | DATE | ISSUANCE

REV #	DATE	ISSUANCE

OWNERSHIP & USE OF DOCUMENTS

These drawings and specifications are the property and copyright of McKay Architects and shall not be used in whole or in part, or shall be assigned to a third party without the express written permission of McKay Architects.
Contractor to verify all information and dimensions in the field prior to start of construction and is to notify McKay Architects of any discrepancies.

**Building
Perspectives**

JOB NO

DATE 1.21.2020

DWG BY RJM

CKD BY MLM

SCALE

1/4" = 1'-0"

A-2.6

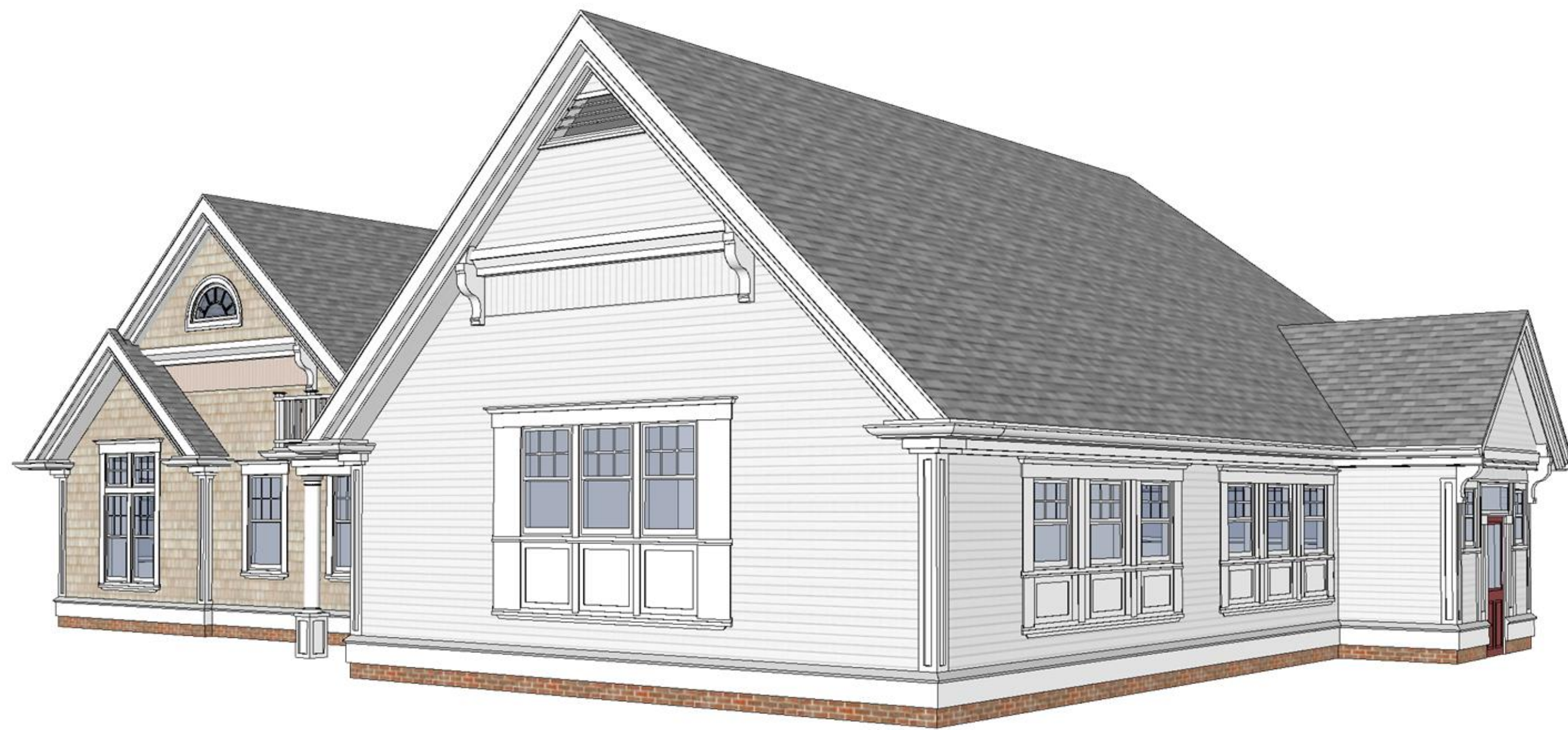

1 | Front & Left Side Perspective
A-2.5



2 | Left & Rear Side Perspective
A-2.5

NOTE:
PERSPECTIVES ARE FOR INFORMATION & MASSING ONLY. REFER TO ELEVATIONS FOR ADDITIONAL INFORMATION.



3 | Rear & Right Side Perspective
A-2.5



4 | Left & Front Side Perspective
A-2.5

FINISH SCHEDULE

ROOM NO.	ROOM NAME	FLOOR	BASE	WALLS				CEILING	REMARKS
				NORTH	EAST	SOUTH	WEST		
001	MECHANICAL	SEALED CONCRETE	VINYL	GWB	GWB	GWB	GWB	ACT	
004	COFFEE BAR	VCT	VINYL	GWB	GWB	GWB	GWB	ACT	
005	STAFF ROOM/ CLASSROOM	VCT	VINYL	GWB	GWB	GWB	GWB	ACT	
006	UNISEX BATHROOM	TILE	TILE	GWB	GWB	GWB	GWB	ACT	
007	UNISEX BATHROOM	TILE	TILE	GWB	GWB	GWB	GWB	ACT	
008	UNISEX BATHROOM	TILE	TILE	GWB	GWB	GWB	GWB	ACT	
009	FINISHED STORAGE	VCT	VINYL	GWB	GWB	GWB	GWB	ACT	
010	HALL	VCT	VINYL	GWB	GWB	GWB	GWB	ACT	
011	FINISHED STORAGE	VCT	VINYL	GWB	GWB	GWB	GWB	ACT	

BASEMENT ROOMS ARE TO BE FINISHED IN ALTERNATE #3

DOOR SCHEDULE BASEMENT DOORS, TRIM AND HARDWARE ARE TO BE INCLUDED IN ALTERNATE #3

DOOR NO.	LOCATION / TYPE	SIZE	DETAILS		REMARKS
			HEAD	JAMB	
1	INTERIOR / (TYP)	3'-0"x7'-0"	WOOD	WOOD	
2	INTERIOR / (TYP)	(2) 2'-6"x7'-0"	WOOD	WOOD	PAIR
3	INTERIOR / (TYP)	(2) 3'-0"x7'-0"	WOOD	WOOD	PAIR
4	INTERIOR / (TYP)	(2) 3'-0"x7'-11"	WOOD	WOOD	PAIR
5	INTERIOR / (TYP)	3'-0"x7'-0"	WOOD	WOOD	"C" LABEL ALARMED DOOR
6	EXTERIOR / LIBRARY	3'-0"x7'-0"	WOOD	WOOD	
7	EXTERIOR / ENTRY HALL	3'-0"x7'-2" w/1'-6" SIDE LITE	WOOD	WOOD	ENTRY
8	EXTERIOR / STAIR #1	3'-0"x7'-0"	WOOD	WOOD	ENTRY
9	EXTERIOR / STAIR #2	3'-0"x7'-11"	WOOD	WOOD	ENTRY
10	INTERIOR / LIBRARY	3'-0"x7'-11" w/2'-0" SIDE LITES	WOOD	WOOD	ENTRY

NOTE:
SHOP DRAWINGS OF DOORS ARE TO BE PROVIDED PRIOR TO ORDERING.

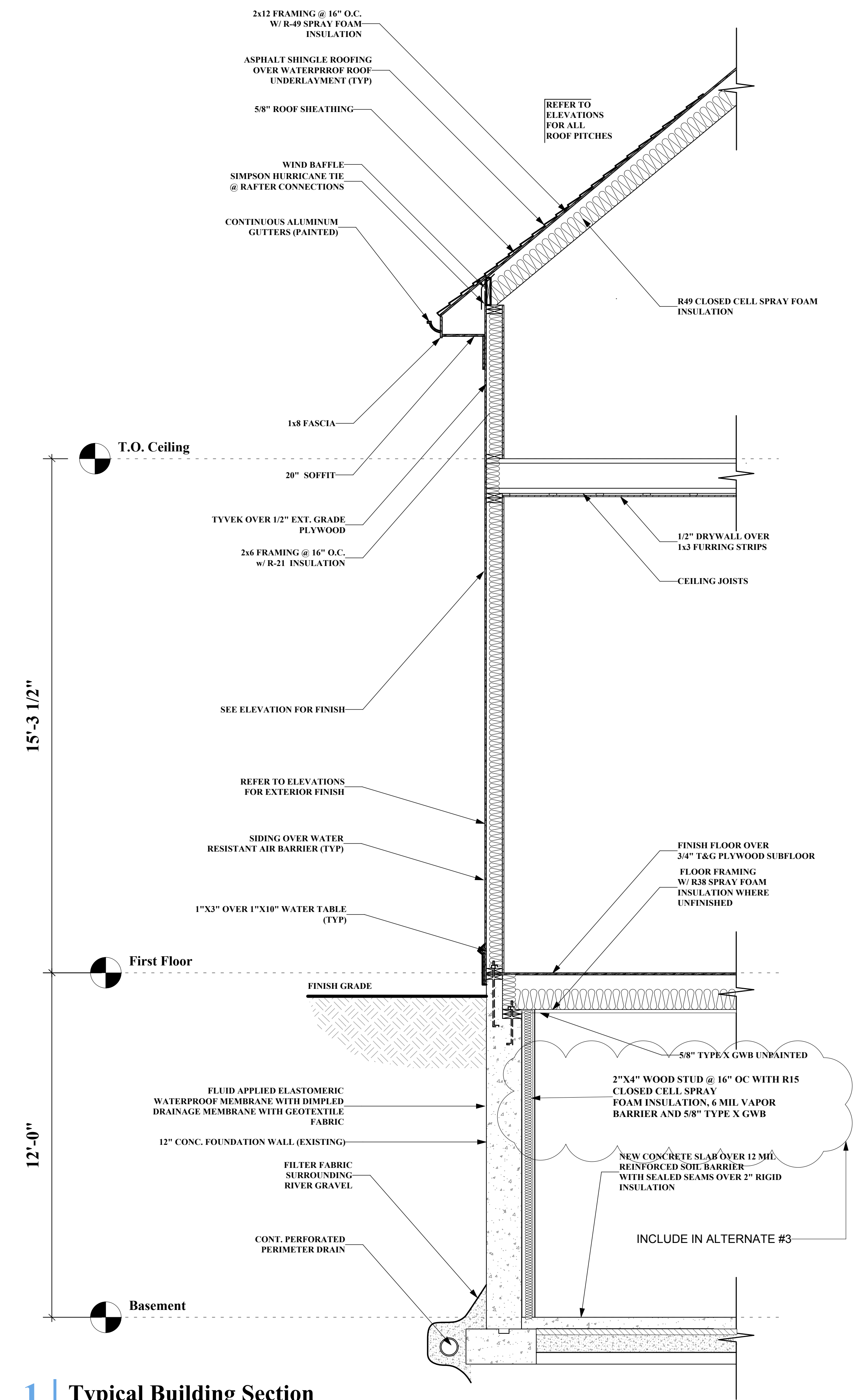

1 Typical Building Section
A-3.2 NOT TO SCALE

ALTERNATE

**Wentworth Hall
Library
Expansion**

Washington Street
Islington, MA

OWNER



35 Bryant Street
Dorham, MA 02026
ph: 781.326.5400
www.mckayarchitects.net

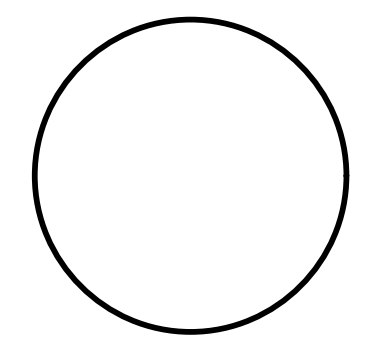

REV #	DATE	ISSUANCE

OWNERSHIP & USE OF DOCUMENTS
These drawings and specifications are the property and copyright of McKay Architects and shall not be used in whole or in part, or shall be assigned to a third party without the express written permission of McKay Architects.
Contractor to verify all information and dimensions in the field prior to start of construction and is to notify McKay Architects of any discrepancies

**Schedules & Typ.
Building Section**

JOB NO.	
DATE	1.21.2020
DWG BY	RJM
CKD BY	MLM
SCALE	AS NOTED

**A-3.2
ALT**

ALL DIMENSIONS SHOWN ARE APPROXIMATE AND ARE SHOWN FOR GENERAL SCOPE ONLY.

Wentworth Hall

Washington Street
Westwood, MA

OWNER

architects
mckay

35 Bryant Street
Dorham, MA 02026
ph: 781.326.5400
www.mckayarchitects.net

KEY:

Demolish - 

To be Relocated - 

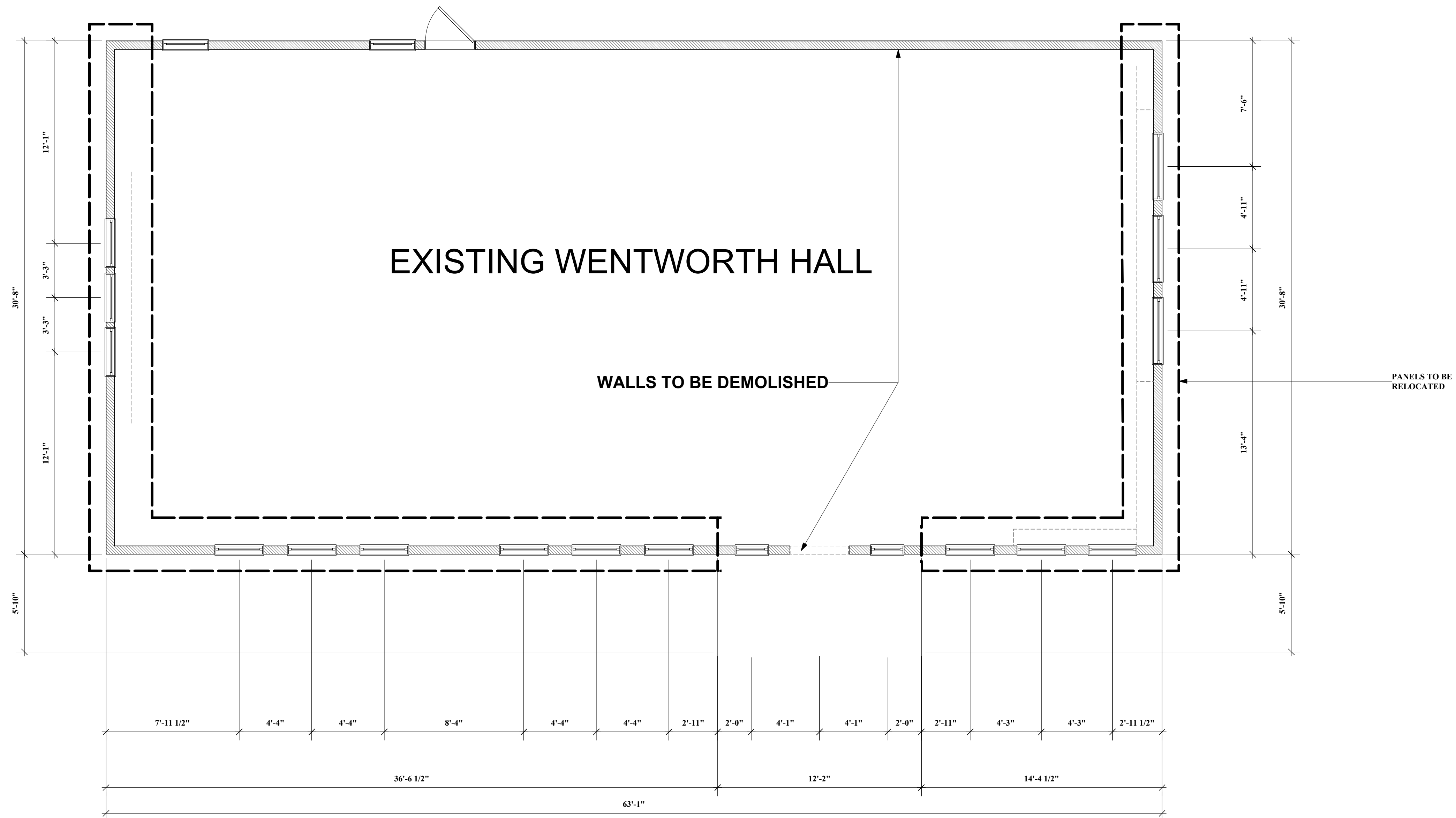

WASHINGTON STREET

1 Existing First Floor Plan
D-1.2 1/4" = 1'-0"

REFER TO SHEET A-2.5 FOR PANELIZATION OF EXISTING WALLS TO BE RELOCATED

HAZARDOUS MATERIALS HAVE BEEN REMOVED UNDER SEPARATE CONTRACT

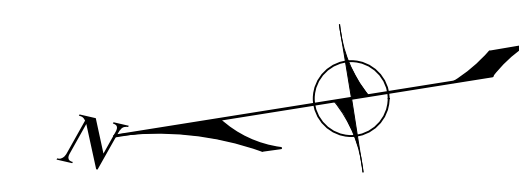

REV # | DATE | ISSUANCE

REV #	DATE	ISSUANCE

OWNERSHIP & USE OF DOCUMENTS

These drawings and specifications are the property and copyright of McKay Architects and shall not be used in whole or in part, or shall be assigned to a third party without the express written permission of McKay Architects.
Contractor to verify all information and dimensions in the field prior to start of construction and is to notify McKay Architects of any discrepancies

First Floor
Demo Plan

JOB NO	
DATE	1.21.2020
DWG BY	RJM
CKD BY	MLM
SCALE	1/4" = 1'-0"

D-1.1

PREMANUFACTURED WOOD TRUSSES CONT.:

- 13. Truss manufacturer shall design all floor and roof truss for all gravity, shear and lateral loads as noted herein and on plans. Add the truss selfweight to these loads.

Design Loads:

Roofs:

Top Chord Live = [30] psf (or snow drift where applicable)
Top Chord Dead = 10 psf
Bottom Chord Dead = 5 psf
Total Load = [50] psf (or snow drift where applicable)
Duration Factor = 1.15

Floors:

Top Chord Live = 40
Top Chord Dead = 20
Bottom Chord Dead = 5
Total Load = 65 psf
Repetitive Factor = 1.15

Corridors:

[40] (80)
20
5
105 psf

Concentrated Loads:

All Concentrated Loads, partial uniform loads, or combinations thereof shall be determined by the truss manufacturer and accounted for in the design of the trusses. The truss system shall be engineered to accept all imposed loads as indicated above. Truss manufacturer will provide calculations indicating additional snow and dead loads for the roof locations with gussets, crickets and valley locations requiring additional roof framing intersections of higher or lower roofs in accordance with ANSI A58.

- 14. Roof trusses shall be designed to withstand uplift due to wind in accordance with section 1611.11 of the Massachusetts State Building Code. [Governing Code.] [These notes]
15. Maximum live load deflection shall be span/240 for roof trusses and span/480 for all others.
16. Each roof truss shall be held down to the top plates with two Simpson seismic and hurricane ties H10 each side of truss or better.
17. All floor trusses shall bear directly above studs at the wall below so axial load shall be transferred from floor to walls through the plate.
18. Verify that surfaces to receive trusses are prepared to required grades and dimensions. Do not begin work until unsatisfactory conditions are corrected.
19. Provide and install rough hardware and metal fastenings as indicated, specified or required for proper installation of trusses. Nails, spikes, screws, bolts and similar items shall be sizes and types to properly secure members in place.
20. [All prefabricated wood floor trusses shall have a center duct opening. Coordinate opening with architect and mechanical drawings.]

LAMINATED VENEER, PARALLEL STRAND & GLULAM LUMBER:

- 1. Material, manufacture, and quality control shall be in accordance with the proposed Commercial Standard "Structural Glued Laminated Timber" of AITC and Current WCLA glued laminated standards.
2. LVL lumber shall be fabricated from ultrasonically graded Southern Pine Veneers in accordance with NER 126.
3. PSL lumber shall be fabricated from long, thin strands or either eastern or western species wood bonded together with a microwave process.
4. Eastern PSL lumber (ES) may include Southern Pine or Yellow Poplar. Western PSL lumber (WS) may include Douglas Fir, Longleaf Pine, Western Hemlock or White Fir.
5. PSL lumber shall be fabricated in parallel strands (PSL) in conformance with NER 292.
6. GL Lumber shall be fabricated from laminated 2x lumber according to standards set forth in NDS and other applicable codes.
7. The members shall have the following minimum design stresses:

Table with columns: Stress Type, Member Type (LVL, PSL, GL). Rows include Modulus of elasticity (E), Flexural stress (fb), Shear modulus of elasticity (G), Compression perpendicular to grain, Horizontal shear perpendicular to wide face, and Horizontal shear parallel to wide face.

- 8. Heal cuts on beams must not overhang inside face of support member.
9. LVL and PSL members shall be fabricated without camber. Glulam members may be cambered to remove dead load deflection.
10. The LVL, PSL and GL members shall be protected from the weather while in storage. Care shall be exercised during handling to prevent damage to the same. A coat of end sealer shall be supplied to ends of all members as soon as practical after end trimming.
11. Adhesives shall comply with ASTM D2559-76 Adhesive for Structural Laminated Products for use under exterior (wet use) exposure conditions.
12. Prior to start of erection, verify the locations and elevation of all bearing surfaces and embedded anchors. Report any deviation to the General Contractor. Do not begin work until unsatisfactory conditions are corrected. Take measurements on site as required for correct fabrication and installation.
13. Fit members together properly and accurately without trimming, cutting or other modification not approved by the Engineer.
14. The completely assembled work shall be inspected and approved by the Architect and Structural Engineer or their designee before being covered, restrained or loaded by other construction.

WOOD FASTENING & HARDWARE:

- 1. Expansion anchors shall be Hilti "kwik bolts" or an approved equal.
2. Adhesive anchors shall be Hilti "HVA anchors" or an approved equal.
3. Powder actuated fasteners shall be Hilti "DS Series Fasteners" or an approved equal.
4. All wood fasteners and hardware shall be as manufactured by Simpson Strong Tie. Alternates shall be submitted to engineer for review.
5. Holdowns, straps and hurricane clips shall be installed according to manufacturer's recommendations.
6. Metal framing anchors shall be used for all connections where shown on the drawings. Provide nails and bolts according to manufacturer's requirements.
7. Connection hardware type to be as follows or approved equal unless noted otherwise on drawings:
Trusjoist on Microlam header - Simpson Type MIT
Trusjoist on Microlam or masonry wall - Simpson Type WM
Microlam to Microlam connection - Simpson Type GLT
Shearwall tie-downs - Simpson Type HD
Microlam on wood or steel column - Simpson Type CC
Sloped rafter to header - Simpson Type LSJ
Flush framed 2x lumber - Simpson Type U or HUS
Steel Strapping - 18 and 20 Ga, 4" & 6" Galv. 33 ksi steel

- 8. Nailing installation and materials are to be in compliance with A.I.T.C., NDS and in accordance with the 2009 International Building Code, Table 2304.9.1.

- 9. Gun nails may be used in lieu of hand nailing. Gun nail sizes shall be as follows:

Table with columns: Penny Weight, Gun Nail Diameter. Rows: 8d (0.113"), 10d (0.125"), 12d (0.125"), 16d (0.133").

- 10. All nails shall be common type u.n.o. Where indicated to be galvanized, nails shall be hot-dipped conforming to ASTM-A153.
11. Nails shall have a minimum penetration into the supporting member of 6 times the wire diameter unless otherwise noted on plans.
12. Edge distance for all nails shall be minimum of 2 times the wire diameter unless otherwise noted on plans.

J/J JOIST SPECIFICATIONS:

- 1. Scope:
a. Procedures for:
1. Designing, installing, securing, bracing, etc., of all joists.
2. Shop drawings:
a. Include the following on submitted shop drawings:
1. Stamp and signature of engineer responsible for preparation of all joist design and layout drawing.
2. Dead and live design loads in plf.
3. Name and trademark of Joist Fabricator and project name and location.
4. Concentrated load requirements have been designed for and shown on documents.
5. Joist connection hardware requirements.
6. Joist block requirements.
7. Web stiffener and squash block requirements.
b. All joist shop drawings must be reviewed and written approval provided, by General Contractor, prior to submittal of shop drawings to Structural Engineer.
c. Shop drawings can not be reviewed by Goldstein-Milano LLC without seal and signature of Joist Company Engineer on all joist engineering sheets and layout drawings.
d. All roof joists must be designed for uplift loads: uplift values at each bearing point must be shown on engineering steel.
3. General:
a. Fabrication of joists shall be designed and manufactured in accordance with NES report no. NER-200, except where this specification exceeds report requirements.
b. Manufacturer's name or trademark and joist type shall be visible on all joists.
c. Joist Fabricator shall have his plant inspected four times per year by an independent testing laboratory. Regulations and copies of inspections made available to owner upon request.
d. Joist Fabricator shall specify hardware required at joist to joist connections.
e. Joists to be designed per Table 16-B (B) (fire sprinkler structural support).
f. Joists shall be designed for a maximum deflection of L/480 (live load) and L/240 (total load).

SUBMITTALS:

- 1. Submit substantiating data for each concrete mix design contemplated for use to the Structural Engineer not less than six weeks prior to first concrete placement. Data for each mix shall, as a minimum, include the following:
a. Mix identification designation (unique for each mix submitted).
b. Statement of intended use for mix.
c. Mix proportions, including all admixture used.
d. Manufacturer's data and/or certifications verifying conformance of all mix materials, including admixtures, with specified requirements.
e. Wet and dry unit weight.
f. Entrained air content.
g. Design slump.
h. Required average strength qualification data per ACI 301 3.9.1 and 3.9.2. Submit separate qualification data for each production facility which will supply concrete to the project.
2. Submit shop drawings for fabrication, bending and placement of concrete and masonry reinforcement. Comply with ACI Detailing Manual (SP 66).
3. Submit Structural Steel Shop Drawings. Clearly indicate profiles, sizes, spacing and location of structural members, connections, attachments, anchorages, framed openings, size and type of fasteners, cambers, and clearances. Indicate welded connections using standard AWS welding symbols. Clearly indicate net weld lengths, sizes and welding sequences. Clearly identify all high strength bolts not required to be tensioned (installed "snug tight" and identified by AISC.
4. Submit Metal Deck Shop Drawings. Indicate decking plan, deck profile, dimensions, gage, anchorage, supports, projections, openings and reinforcement, finishes, applicable details and accessories, type, locations and size of welds.
5. Furnish wood truss shop drawings. Indicate truss framing plans, pitch, span and spacing of trusses, gage thickness, nominal sizes and location of connectors at joints, bearing and anchored details, framed opening, permanent bracing and bridging and all related items. Submit Manufacturer's instructions on lateral bracing with shop drawings. Submit calculations performed by (Massachusetts) professional engineer.

INSPECTION CONCRETE:

- 1. Concrete inspection and testing will be made in accordance with building code requirements, and Contract Documents, and will include the following:
a. Testing concrete for strength, slump, air content, temperature, and unit weight.
b. Marking and testing concrete cylinders, including furnishing cylinder container for specimen.
c. Transporting and storing of all specimens involved in testing and inspection. Test cylinders are to be transported to laboratory not later than 24 hours and not earlier than 16 hours after casting.
d. Inspection of mixing and placing of concrete at the site, including record of amount and location of concrete placement, method of placing concrete, and any other pertinent information.
2. The Testing laboratory will take specimens as follows: At least one set of four cylinders for each 50 cubic yards or fraction thereof of each class of concrete, but not less than one set for any one day's operation.
a. For concrete placed by plumbing, test specimen and concrete used for determination of slump, air content and weight are to be taken at the point of placement of concrete into the forms.
b. Samples will be obtained in accordance with ASTM C172.
c. Marking, curing and subsequent handling of test cylinders, except as modified herein, shall be in accordance with ASTM C31. Testing shall be in accordance with ASTM C39.
d. The cylinder shall be placed in laboratory storage under moist curing conditions at approximately 70 degrees F within 24 hours after molding, and maintain therein until tested. Tests will be as follows:
1) One cylinder shall be tested at 7 days for information.
2) Two cylinders shall be tested at 28 days for acceptance. The acceptance test results shall be the average strength of these two cylinders.
3) One cylinder shall be kept for eventual testing at 56 days to verify any marginal results of 28-day tests. If not required to be tested, cylinder will be discarded after 28 days.

- 3. Test Reports: Reports of cylinder tests shall be submitted as specified herein within five days of laboratory testing. Test reports shall, as a minimum, include:
a. Results of field testing at time of sampling including date and time of sampling, amount of water added at site prior to sampling, ambient air temperature and concrete temperature, concrete slump and air content, and concrete wet unit weight.
b. Results of laboratory testing including date test specimen were transported to laboratory, date and age of concrete at time of testing, compressive strength of each cylinder tested, coverage compressive strength of tested cylinders, and specified design strength of concrete represented by the test.
4. Additional Testing: Contractor shall bear the cost of testing and inspection resulting as consequence of the following:
a. Work not in compliance with the Contract Documents.
b. Testing requested by the Contractor or Subcontractor such as additional cylinders for early breaks, etc.
c. Testing to verify the adequacy of work done without prior notice, without proper supervision, or contrary to standard construction practice.
5. Reinforcing Steel Inspection: Concrete reinforcing shall be inspected prior to closing of concrete form work or placing of concrete. Inspector to verify size, spacing, quantity of reinforcing per latest contract documents.

INSPECTION GROUT:

- 1. Prepare test specimens in accordance with the requirements of the governing building code. Comply with ASTM C107.
2. For each day's production prepare, test and submit compression test results of one set of 3 (2" x 2") cubes made from each type of grout used in the field.

INSPECTION REINFORCED UNIT MASONRY:

- A. Prepare test specimens in accordance with the requirements of the governing building code.
B. Tests, consisting of three prisms each made in the field from materials currently in use, shall be conducted for each 5000 square feet, or fraction thereof, of structural Unit Masonry throughout the course of construction. Not less than three such tests shall be conducted for the project.
C. Mortar and grout tests shall be conducted on materials used to construct the first set of three prisms in B above. In the event such tests fail to achieve the required strength, perform additional testing as required by the Structural Engineer.
D. Testing Agency shall provide special inspection complying with the requirements of the governing building code during the construction of the following work:
All CMU Walls
E. Special inspection shall be performed by personnel experienced in Unit Masonry construction and acceptable to the Architect and Structural Engineer. The special inspector shall observe the preparation of all Unit Masonry prisms, and grout and mortar specimens.
1. Low-lift grouting techniques, the special inspector shall observe and verify compliance with contract documents for the placement of Unit Masonry units, reinforcing and grout on a schedule of at least twice each day that Unit Masonry construction is in progress.
2. High-lift grouting techniques, the special inspector shall observe and verify compliance with contract documents for the placement of Unit Masonry units, grout, and reinforcing immediately prior to closing of clean-outs for each section of Unit Masonry to be grouted; he shall continuously observe the grouting operation of the first 1000 square feet of Unit Masonry installed and on a schedule of twice for each three days that grouting operations are in progress thereafter.
3. Special inspection shall also include:
a. Verify size and spacing of all reinforcing.
b. Verify all reinforcing is placed with required lap and development lengths, and is located properly in grouted cells.

INSPECTION - STRUCTURAL STEEL:

- 1. Testing and inspection will be made by an approved testing laboratory selected and paid by the owner. Contractor shall furnish testing agency access to work, facilities and incidental labor required for testing and inspection. Retention by the Owner of an independent testing agency shall in no way relieve the Contractor of responsibility for performing all work in accordance with the contract requirements.
2. Furnish the Testing Agency with the following:
a. A complete set of shop and erection drawings.
b. 48 hour advance notice of complete work prior to spray fireproofing (where applicable).
c. Full and ample means and assistance for testing all material.
d. Proper facilities, including scaffolding, temporary work platforms, etc., for inspection of the work in the mills, shop and field.
3. Each person installing connections shall be assigned an identifying symbol or mark, and all shop and field connections shall be identified so that the inspector can refer back to the person making the connection.
4. The Testing Agency's inspector will perform his duties in such a way that neither fabrication nor erection is unnecessarily delayed or impeded. In no case will the inspector recommend or prescribe the method of repair of a defect.
5. Field inspection by the Testing Agency of erected steel will be such as to assure that the work conforms to specified requirements and will include:
a. Inspection of welding as required herein.
b. Ascertainment of proper fit and alignment.
c. Ascertainment that the welding is performed only by welding operators and welders who are properly certified. The Testing Agency shall witness such qualification testing of welding operators and welders, as may be required.
6. Welding and Materials:
Inspection of welding by the Testing Agency will be such as to assume that the work conforms to specified requirements, and will include:
a. Ascertainment that electrodes used for manual shielded metal-arc welding and electrodes used for submerged arc welding conform to the requirements of this section.
b. Ascertainment that the approved welding procedure and the approved welding sequence is followed.
c. Ascertainment that the welding is performed only by welding operators and welders who are properly certified. The Testing Agency shall witness such qualification testing of welding operators and welders, as may be required.
d. Ascertainment that the fit-up, joint preparation, size, contour, extent or reinforcement, and length and location of welds conform to specified requirements of the contract drawings, and that no specified welds are omitted or unspecified welds added without approval.
7. The Testing Agency shall test field welds in accordance with AWS D1.1 as follows:
a. All welds 100% visual.
b. Fillet Welds (u.n.o.): One spot test per member, magnetic particle.
c. Partial Penetration Welds: One spot test per weld, magnetic particle.
d. Full Penetration Welds: All completed penetration groove welds contained in joint and splices shall be tested one hundred percent (100%) by ultrasonic testing.
8. Additional testing will be required:
a. If more than 10 percent of the tested welds are rejected, then an additional 10 percent of all such welds shall be tested using the same method. This 10 percent additional testing process shall be repeated until the rejection rate drops below 1 to 10.
b. All cost of additional inspection required by this paragraph shall be done at the Contractor's expense.
9. In addition, if defective welds are discovered, the remaining uninspected welds shall receive such ultrasonic or magnetic particle inspection as may be required by the Structural Engineer.
10. The welding inspector will have the authority to reject weldments. Such rejection may be based on visual inspection where in his opinion the weldment would not pass a more detailed investigation.
11. Reports by the Testing Agency's inspector will contain, as a minimum, an adequate description of each weld tested, the identifying mark of the welder responsible for the weld, a critique of any defects noted by visual inspection or testing, and a statement regarding the acceptability of the weld tested, as judged by current A.W.S. standards. Reports shall be distributed as early as possible but not later than one work week after the tests have been performed. The Structural Engineer shall be notified, in the judgment of the inspector, test results require immediate comment.

INSPECTION - STRUCTURAL STEEL CONT.:

- 12. High Strength Bolts:
a. The inspector shall determine the appropriate requirements of Sections J3 and M2 of the AISC "Specifications" are met.
b. Standard Bolts:
1) Verify Contractor's testing of installation procedures (turn of the nut) to achieve specified bolt tensions for each lot of bolts. Contractor to provide a calibrated device capable of indicating bolt tension.
2) Verify required bolt tension for all bolts.
3) If rejectable bolts are found in any connection all the remaining bolts in that connection shall be inspected for tightness. Inspection procedure shall be in accordance with "Specification for Structural Joints Using ASTM A325 or A490 Bolts" approved by Research Council on Riveted and Bolted Structural Joints of the Engineering Foundation (Research Council on Structural Connections). Cost of additional inspection required by this paragraph shall be borne by the contractor.
c. Tension Control (self-indicating) Bolts:
1) Verify Contractor's testing of bolt capacity to achieve specified tensions for each lot of bolts.
2) Perform a visual inspection of all high strength bolted connections to assure that all torque-off lines have been sheared.

INSPECTION METAL DECKING:

- A. Metal Deck:
1. The Testing Agency will visually inspect all metal deck to observe that the material is not damaged and has been installed to the requirements of the contract documents.
2. The Testing Agency shall visually inspect all deck welds for size and spacing and verify they meet the requirements of the contract documents prior to being covered by other work.

Wentworth Hall Library Expansion 918 Washington Street Islington, MA

OWNER

mckay architects

35 Bryant Street Dedham, MA 02026 ph. 781.326.5400 www.mckayarchitects.net

GOLDSTEIN-MILANO LLC Structural Engineers

125 Main Street Reading, MA 01867 781-670-9990 (p) 781-670-9939 (f)

Table with columns: REV #, DATE, ISSUANCE. Multiple empty rows for revision tracking.

OWNERSHIP & USE OF DOCUMENTS

These drawings and specifications are the property and copyright of McKay Architects and shall not be used in whole or in part, or shall be assigned to a third party without the express written permission of McKay Architects. Contractor to verify all information and dimensions in the field prior to start of construction and is to notify McKay Architects of any discrepancies.

General Notes III

Table with columns: JOB NO, DATE, DWG BY, CKD BY, SCALE. Values: 18197.00, 05.29.19, DAD, BRG, AS NOTED.

S-0.3

TENSION DEVELOPMENT LENGTH (Lap Class A) AND LAP SPLICE LENGTHS (Lap Class B)
FOR GRADE 60 DEFORMED REINFORCING BARS (inches)

$f'_c = 3000$ PSI, NORMAL WEIGHT CONCRETE

BAR SIZE	LAP CLASS	CONCRETE COVER ≥ 0.75 in. CLEAR BAR SPACING ≥ 15 in.				CONCRETE COVER ≥ 1.00 in. CLEAR BAR SPACING ≥ 2.0 in.				CONCRETE COVER ≥ 1.50 in. CLEAR BAR SPACING ≥ 3.0 in.				CONCRETE COVER ≥ 2.00 in. CLEAR BAR SPACING ≥ 4.0 in.				CONCRETE COVER ≥ 3.00 in. CLEAR BAR SPACING ≥ 6.0 in.			
		UNCOATED		EPOXY-COATED		UNCOATED		EPOXY-COATED		UNCOATED		EPOXY-COATED		UNCOATED		EPOXY-COATED		UNCOATED		EPOXY-COATED	
		TOP ¹	OTHER	TOP ¹	OTHER	TOP ¹	OTHER	TOP ¹	OTHER	TOP ¹	OTHER	TOP ¹	OTHER	TOP ¹	OTHER	TOP ¹	OTHER	TOP ¹	OTHER	TOP ¹	OTHER
#3	A	13	12	17	15	13	12	17	15	13	12	16	12	13	12	16	12	13	12	16	12
	B	17	16	22	20	17	16	22	20	17	16	20	16	17	16	20	16	17	16	20	16
#4	A	22	17	28	25	17	13	23	20	17	13	21	16	17	13	21	16	17	13	21	16
	B	28	22	37	32	23	17	29	26	23	17	27	21	23	17	27	21	23	17	27	21
#5	A	32	24	41	37	26	20	34	30	22	17	28	25	22	17	26	20	22	17	26	20
	B	41	32	54	47	33	26	44	38	28	22	37	32	28	22	34	26	28	22	34	26
#6	A	43	33	56	50	35	27	46	41	26	20	34	30	26	20	34	30	26	20	31	24
	B	56	43	73	64	46	35	60	53	34	26	44	39	34	26	44	39	34	26	40	31
#7	A	69	53	90	80	57	44	75	66	43	33	55	49	38	29	49	43	38	29	45	35
	B	90	69	117	104	74	57	97	86	55	43	72	64	49	38	64	56	49	38	59	45
#8	A	86	66	112	99	72	55	93	82	54	41	70	62	43	33	56	50	43	33	52	40
	B	111	86	146	128	93	72	121	107	70	54	91	80	56	43	73	64	56	43	67	52
#9	A	104	80	136	120	87	67	114	101	66	51	86	76	53	41	70	61	48	37	63	56
	B	135	104	176	155	113	87	148	131	86	66	112	99	69	53	90	80	63	48	82	73
#10	A	125	96	163	144	106	81	138	122	81	62	106	93	66	51	86	76	55	42	71	63
	B	162	125	212	187	137	106	179	158	105	81	137	121	85	66	111	98	71	55	93	82
#11	A	146	113	191	169	125	96	163	144	97	74	126	111	79	61	103	91	61	47	79	70
	B	190	146	248	219	162	125	212	187	125	97	164	145	102	79	134	118	79	61	103	91

- NOTES:
1. TOP BARS ARE HORIZONTAL BARS WITH MORE THAN 12 INCHES OF CONCRETE CAST BELOW THE BARS.

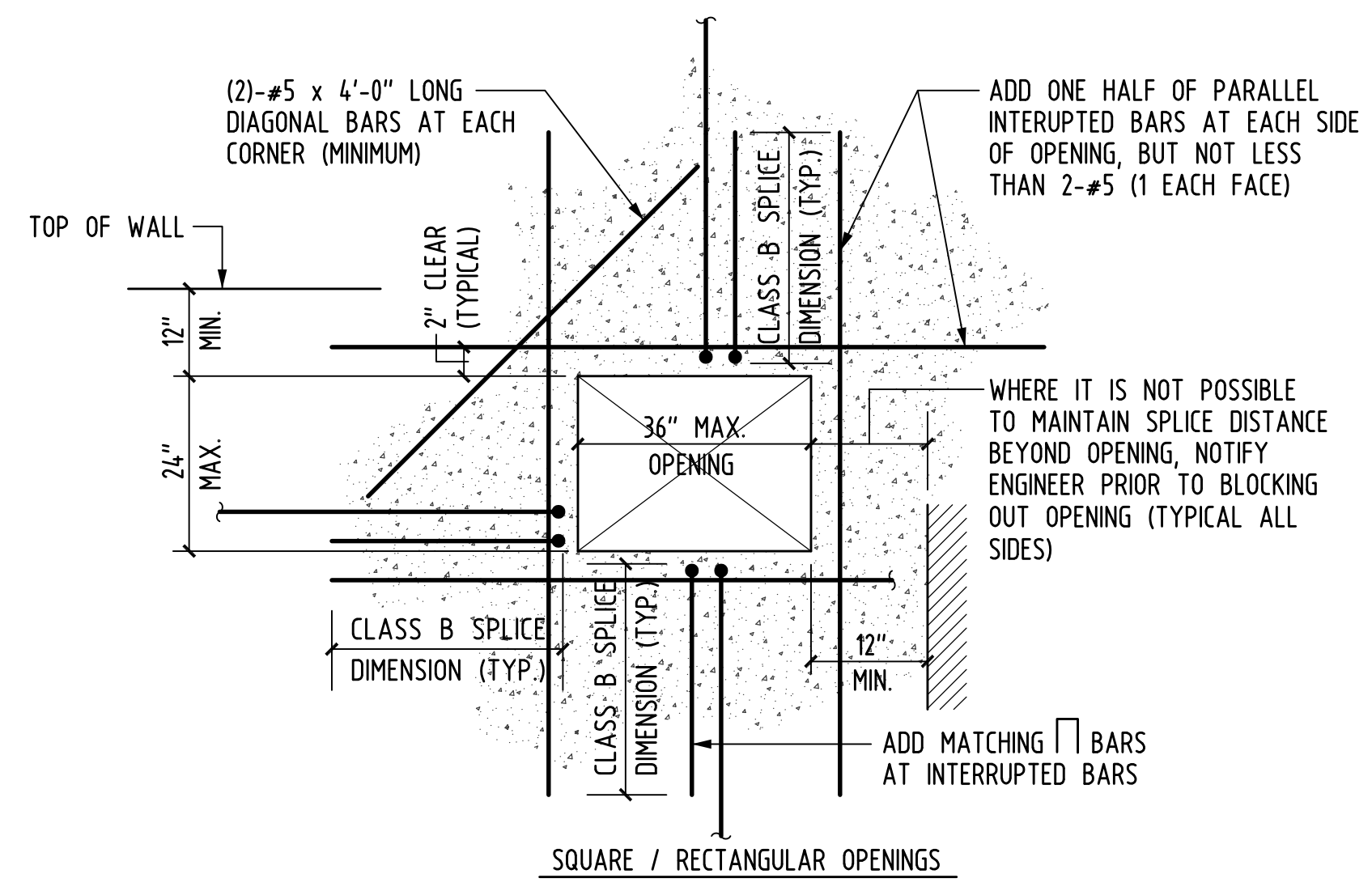

- NOTE:
FOR OPENING THAT FIT BETWEEN HORIZONTAL & VERTICAL WALL REINF. NO ADDITIONAL REINF. REQUIRED.

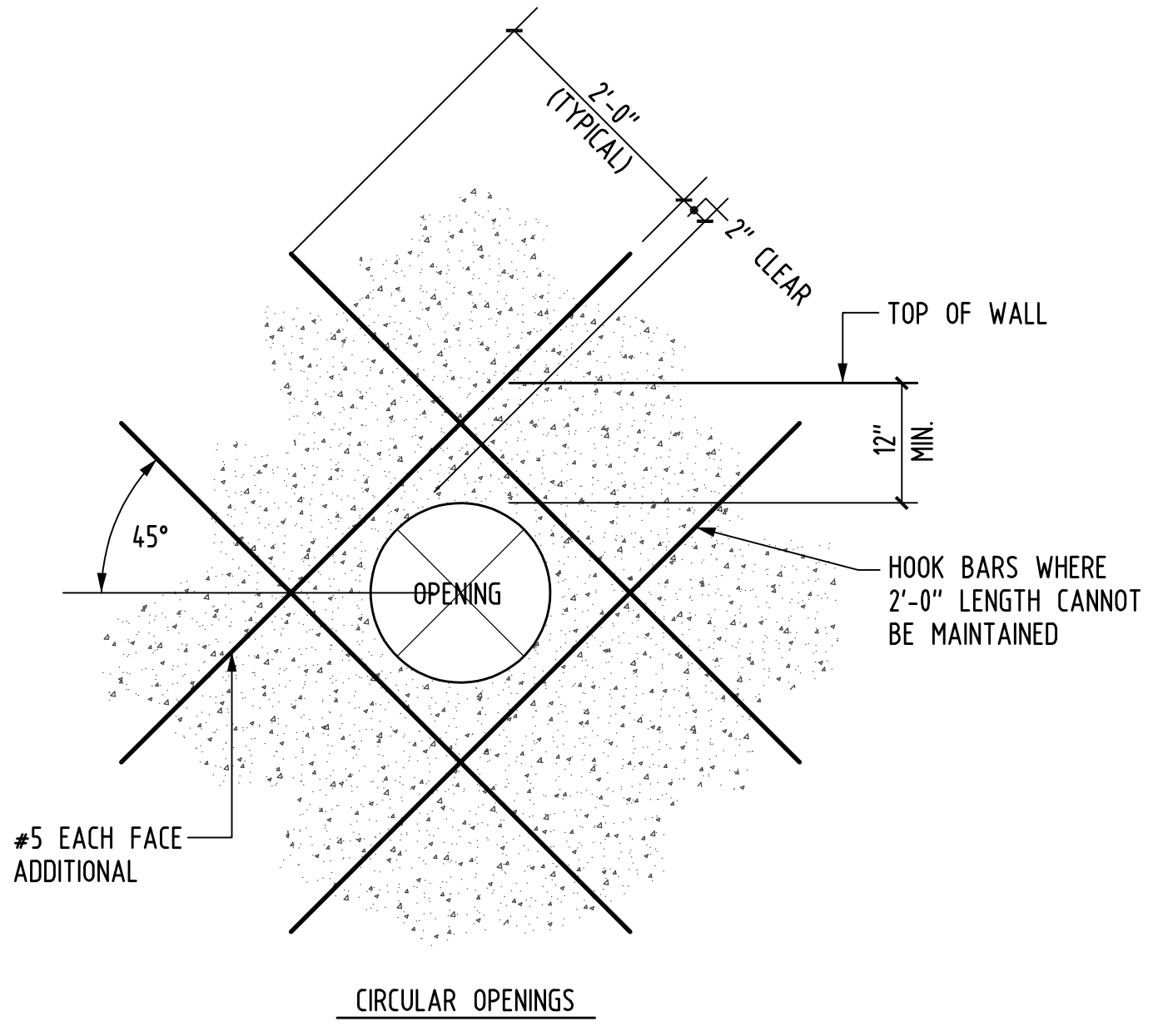

- NOTES:
1. FOR OPENING DIAMETER $\leq 6"$ THIS DETAIL NOT REQUIRED.
2. USE AS SHOWN FOR OPENING SIZE LESS THAN WALL REINFORCING CLEAR BAR SPACING, ELSE APPLY SQUARE OPENING DETAIL AT LEFT.
3. AT MULTIPLE OPENINGS MAINTAIN $3 \times$ DIA. CLEAR SPACING & SUBMIT FOR REINFORCING REVIEW.

TYPICAL REINFORCING AT OPENINGS IN REINFORCED CONCRETE WALLS

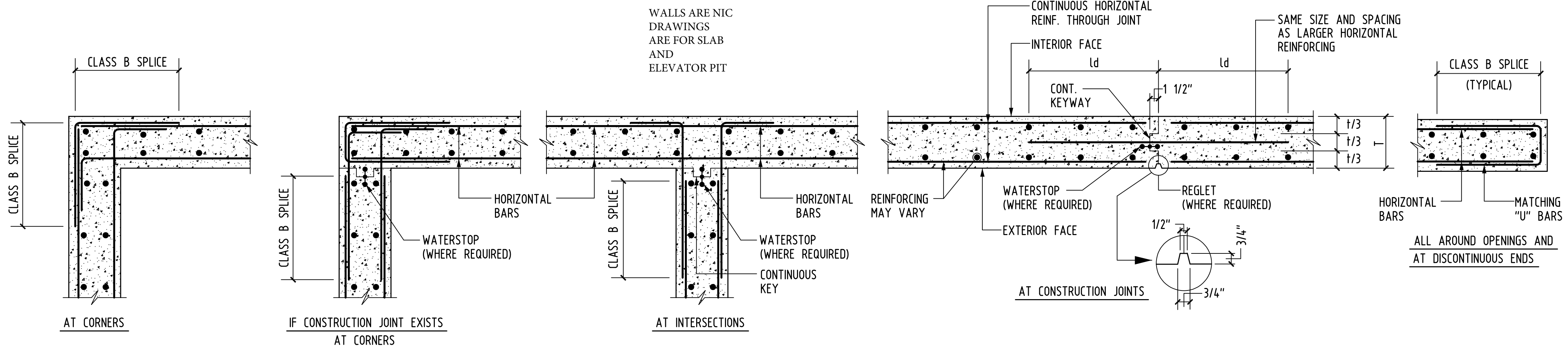

TYPICAL CONCRETE WALL DETAILS

- NOTES:
1. ALL HOOKS STANDARD U.O.
2. PROVIDE CONT. WATERSTOP AT ALL EXPOSED JOINTS ABOVE GRADE.

DRILLED-IN AND EPOXY DOWEL EMBEDMENT SCHEDULE

REINFORCING SIZE	UNCOATED BARS EMBEDMENT DEPTH (INCHES)
#4 BAR	6
#5 BAR	7
#6 BAR	8
#7 BAR	10
#8 BAR	12
#9 BAR	13
#10 BAR	16

- NOTES:
1. TO BE USED WHERE CAST IN PLACE DOWELS ARE OMITTED. USE PER ENGINEER OF RECORD DIRECTION ONLY.

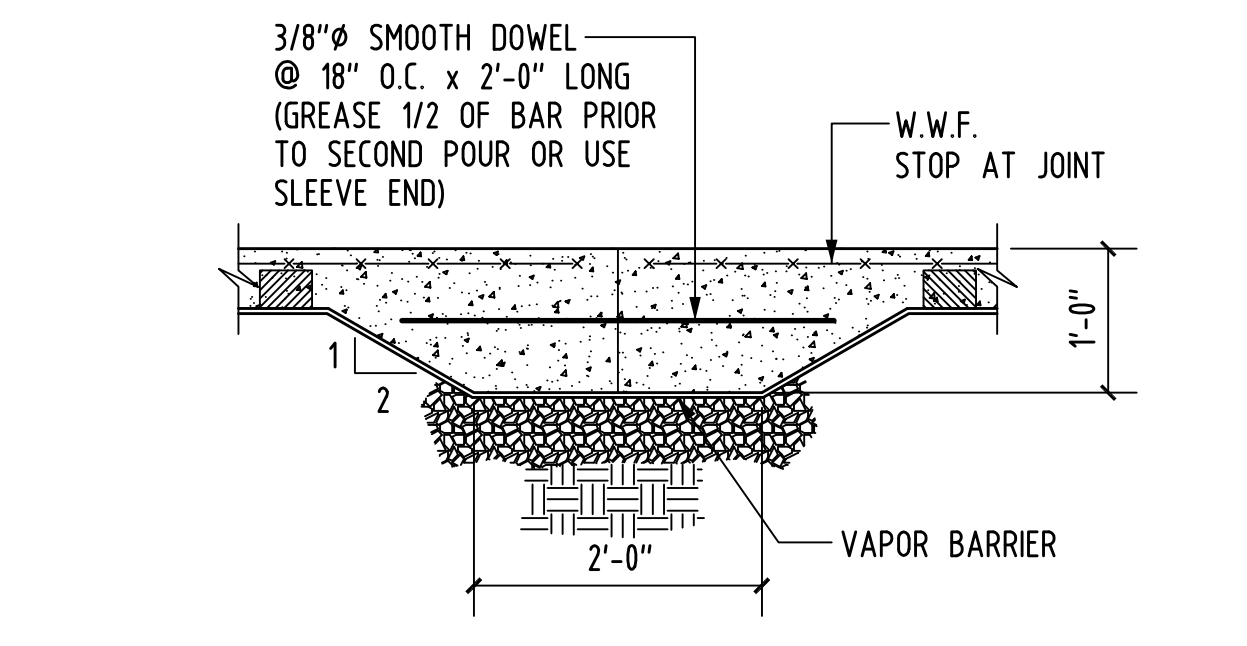

CONSTRUCTION JOINT AT SLAB ON GRADE

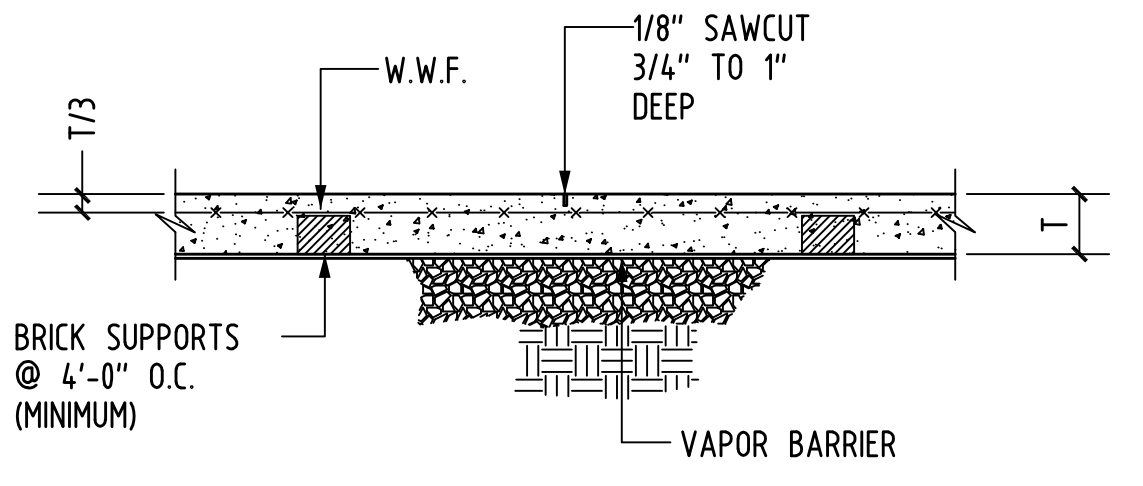

CONTROL JOINT AT SLAB ON GRADE

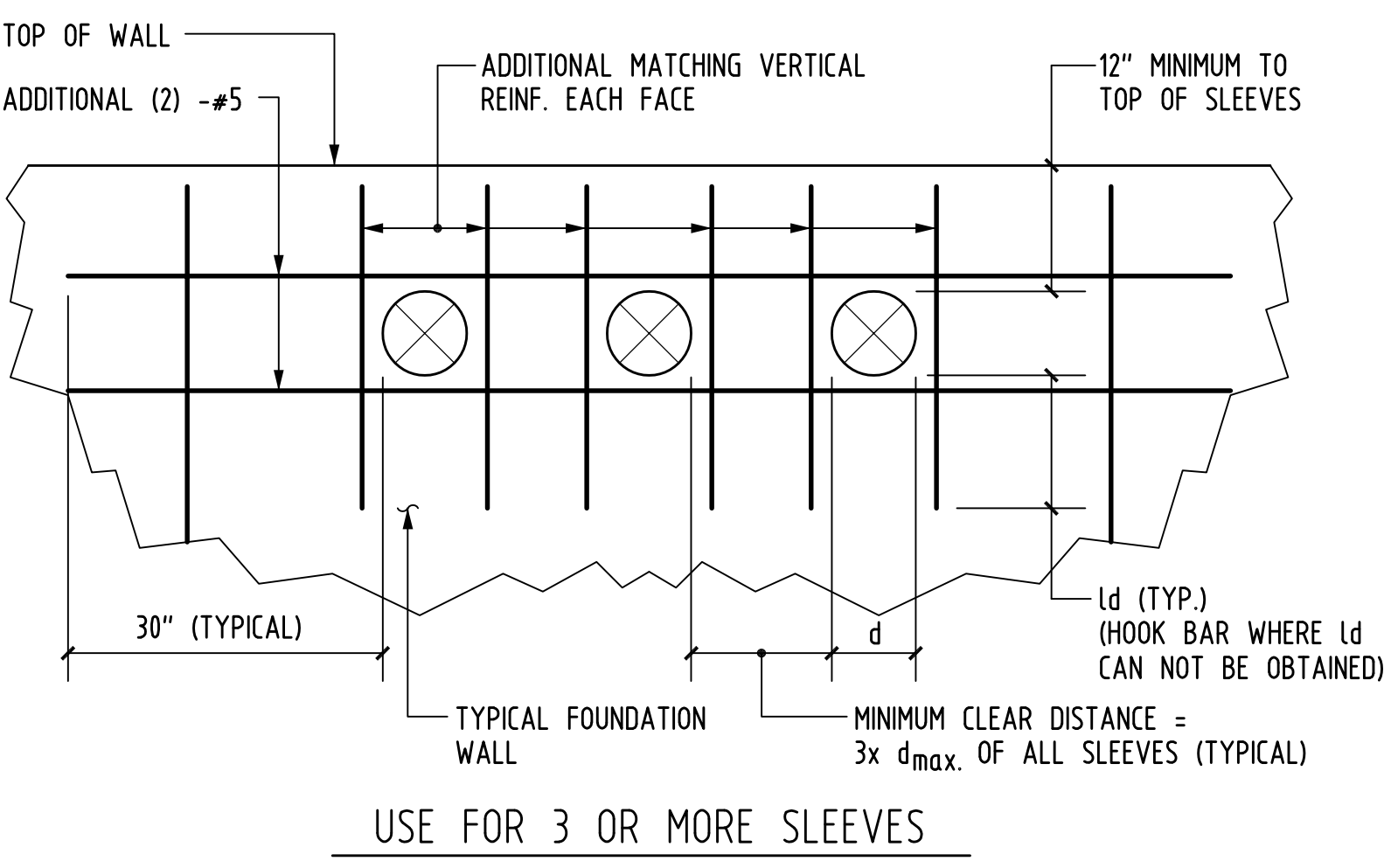

TYPICAL MULTI-SLEEVE DETAIL AT FOUNDATION WALL

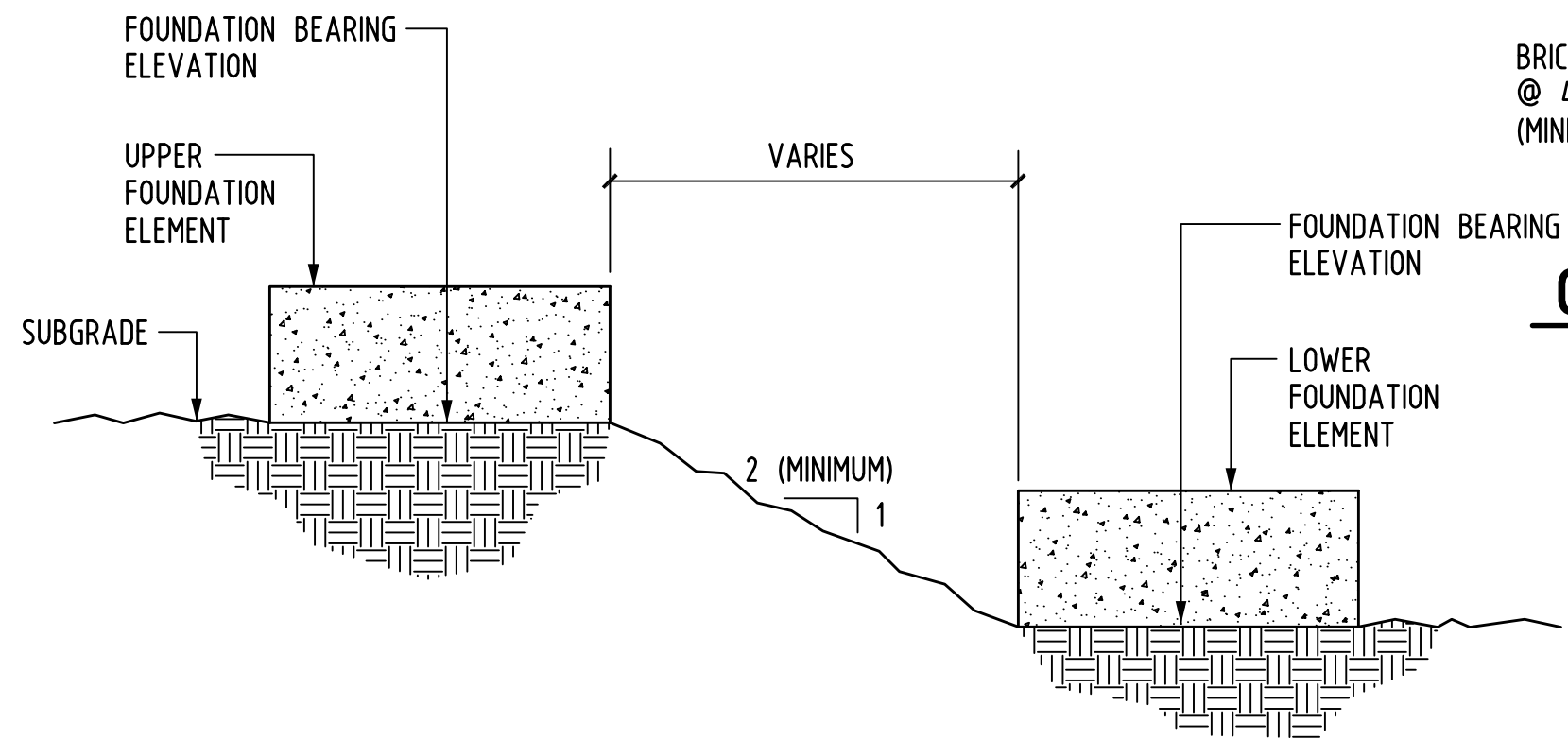

ALLOWABLE GRADE CHANGE AT ADJACENT SOIL BEARING FOUNDATIONS

- NOTE:
REFER TO PROJECT GEOTECHNICAL REPORT FOR ADDITIONAL REQUIREMENTS.

**Wentworth Hall
Library
Expansion**
918
Washington Street
Islington, MA

OWNER

architects
mckay

35 Bryant Street
Dedham, MA 02026
ph. 781.326.5400
www.mckayarchitects.net

GOLDSTEIN-MILANO LLC
Structural Engineers

125 Main Street
Reading, MA 01867
781-670-9990 (p)
781-670-9939 (f)

REV #	DATE	ISSUANCE

OWNERSHIP & USE OF DOCUMENTS
These drawings and specifications are the property and copyright of McKay Architects and shall not be used in whole or in part, or shall be assigned to a third party without the express written permission of McKay Architects.
Contractor to verify all information and dimensions in the field prior to start of construction and is to notify McKay Architects of any discrepancies

**Concrete
Details I**

JOB NO
18197.00
DATE
05.29.19
DWG BY
DAD
CKD BY
BRG
SCALE
AS NOTED

S-3.1

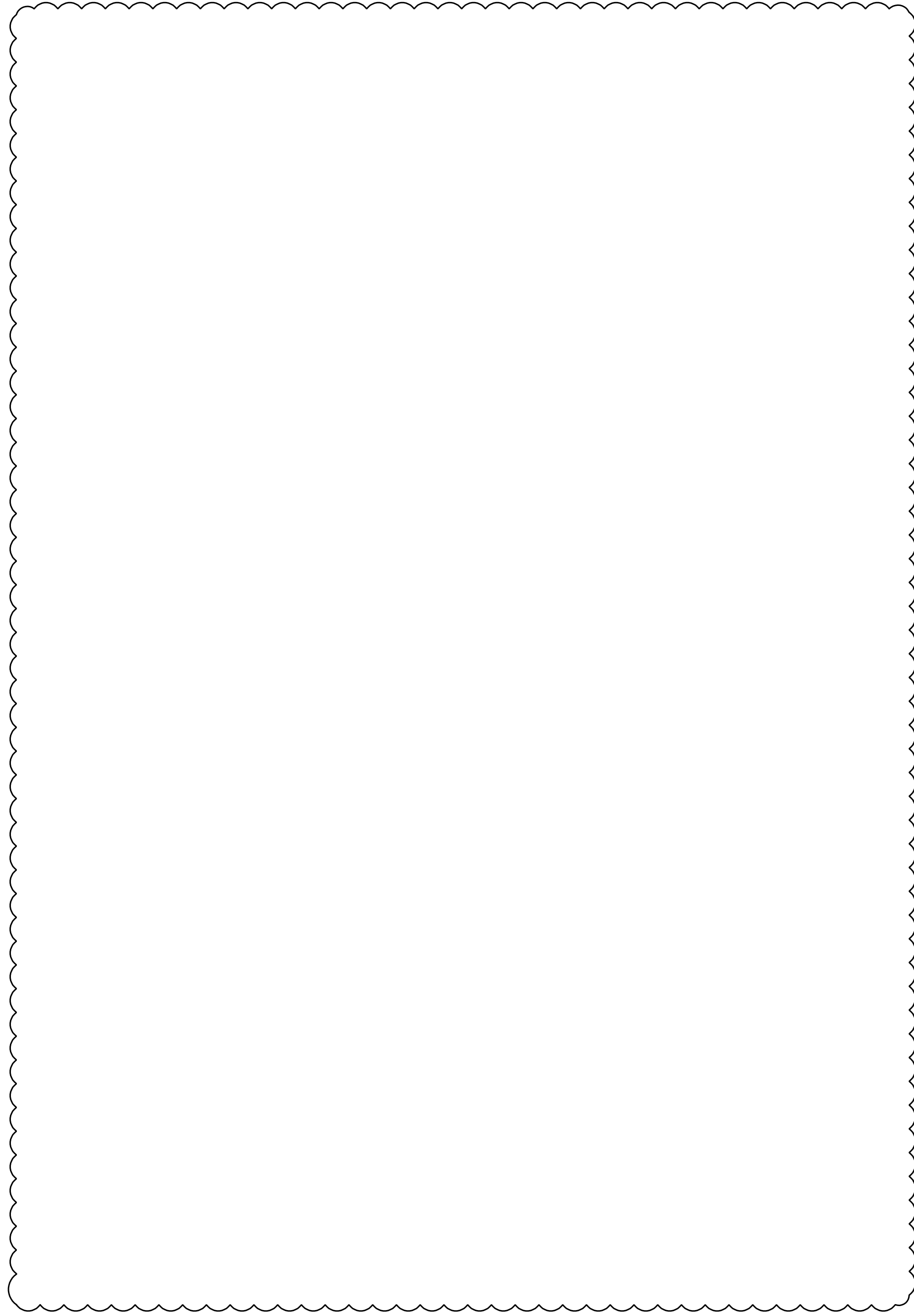

1

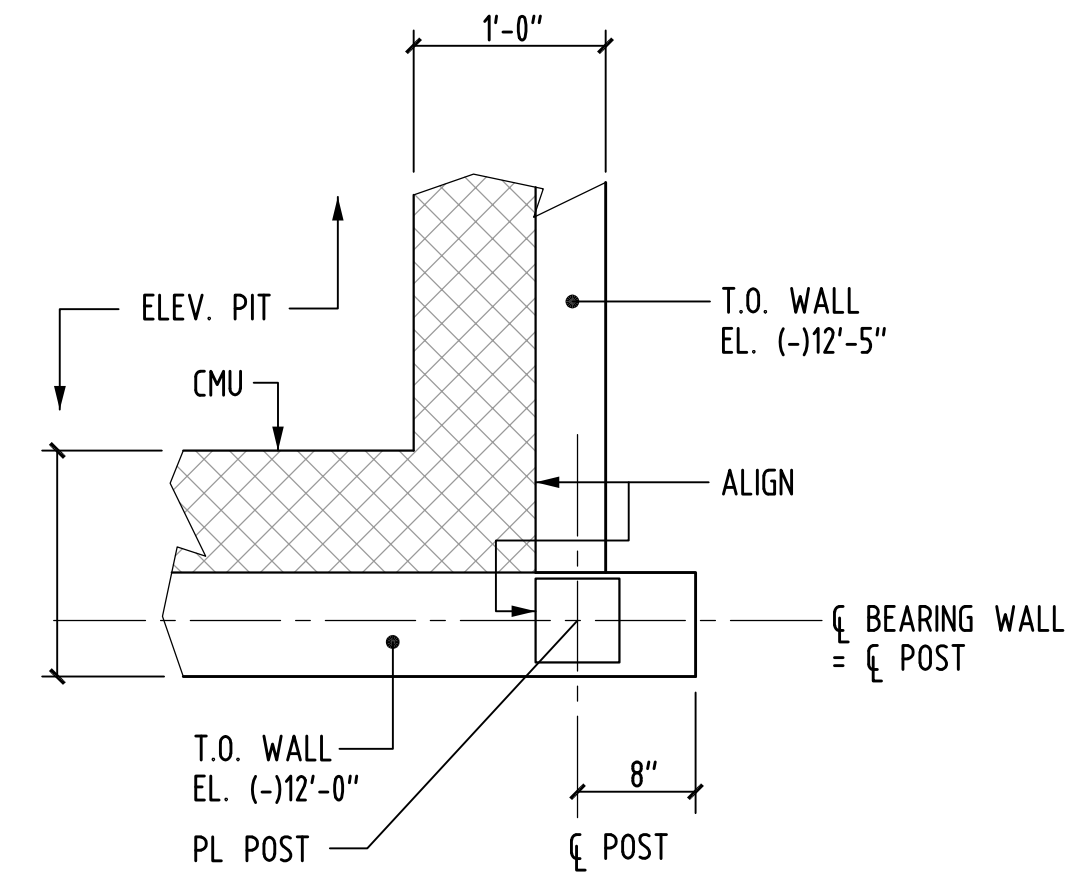

PIER P1
SCALE: 1"=1'-0"

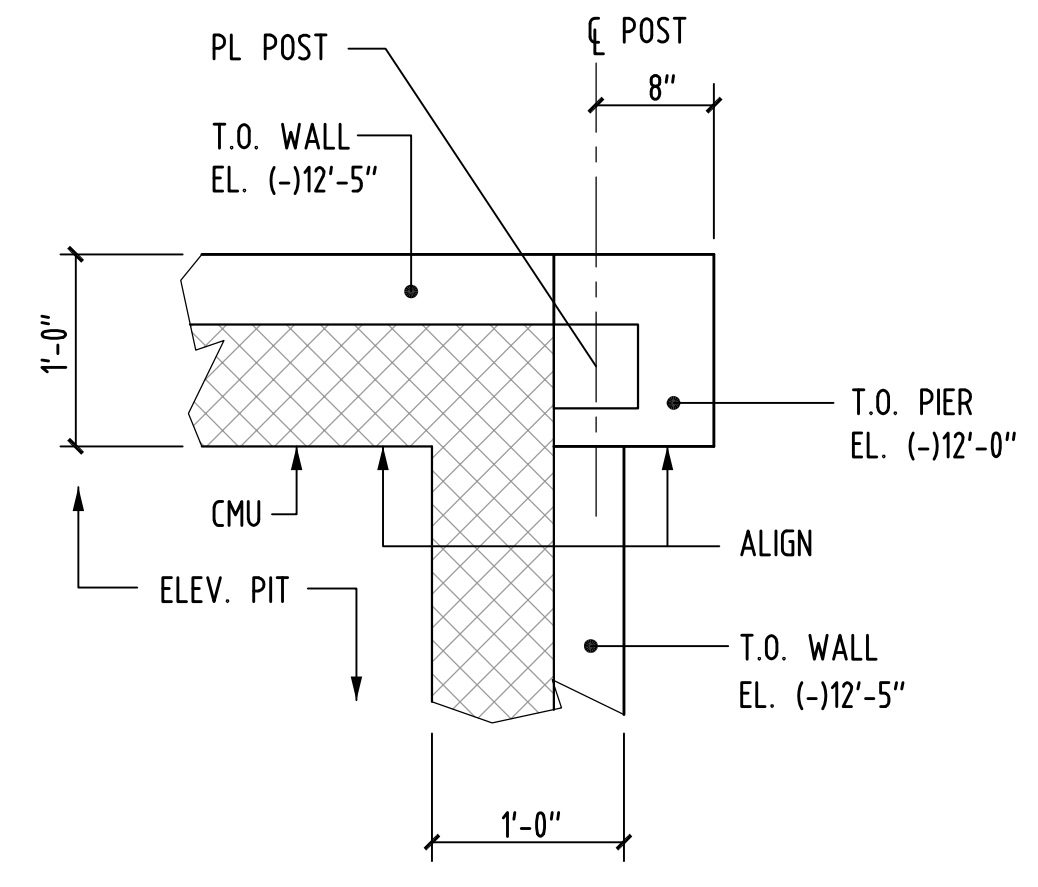

PIER P2
SCALE: 1"=1'-0"

**Wentworth Hall
Library
Expansion
918
Washington Street
Islington, MA**

OWNER

architects
mckay

35 Bryant Street
Dedham, MA 02026
ph. 781.326.5400
www.mckayarchitects.net

GOLDSTEIN-MILANO LLC
Structural Engineers

125 Main Street
Reading, MA 01867
781-670-9990 (p)
781-670-9939 (f)



ISSUED FOR FOUNDATION PERMIT
NOVEMBER 5, 2019

REV #	DATE	ISSUANCE
1	12/23/19	REVISION #1

OWNERSHIP & USE OF DOCUMENTS
These drawings and specifications are the property and copyright of McKay Architects and shall not be used in whole or in part, or shall be assigned to a third party without the express written permission of McKay Architects.
Contractor to verify all information and dimensions in the field prior to start of construction and is to notify McKay Architects of any discrepancies

**Concrete
Details IV**

JOB NO	18197.00	S-3.4
DATE	05.29.19	
DWG BY	DAD	
CKD BY	BRG	
SCALE	AS NOTED	

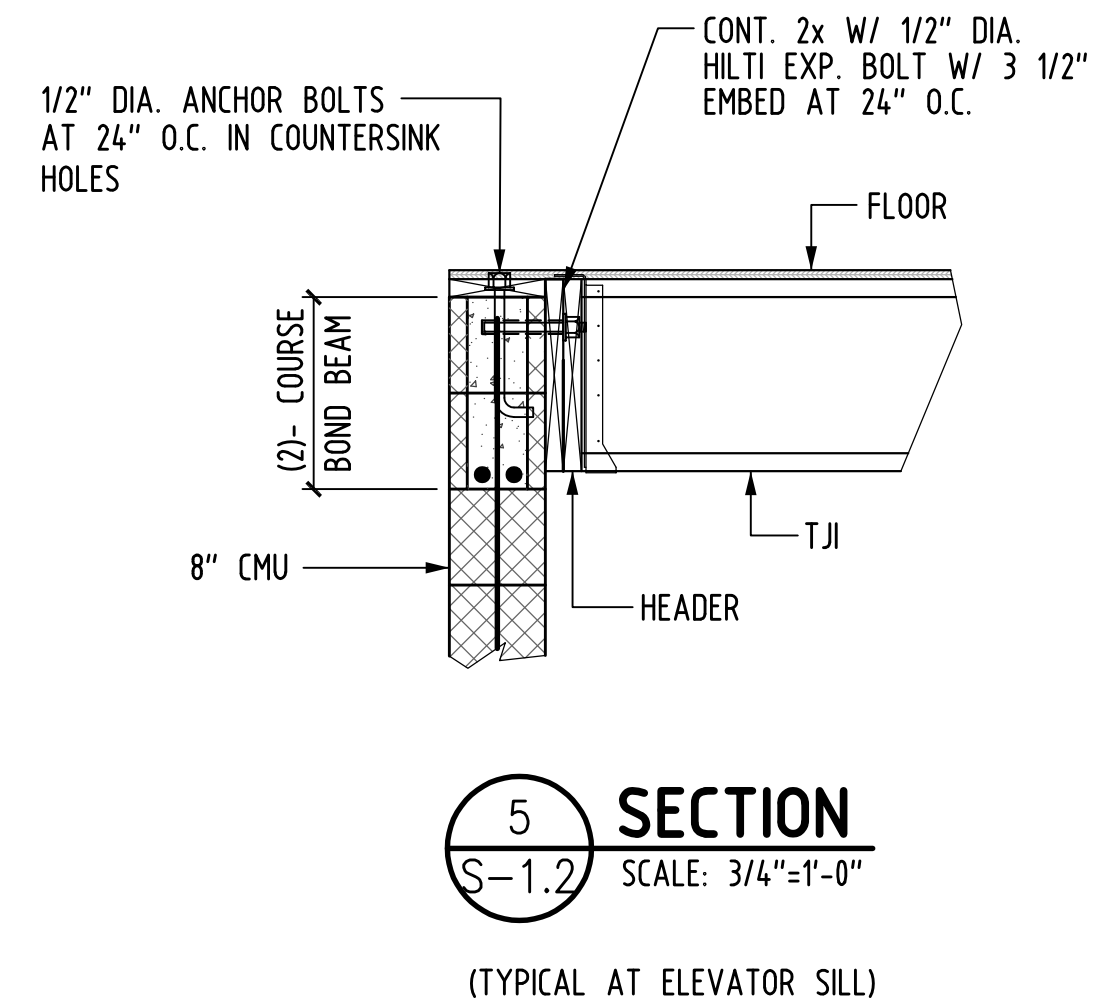
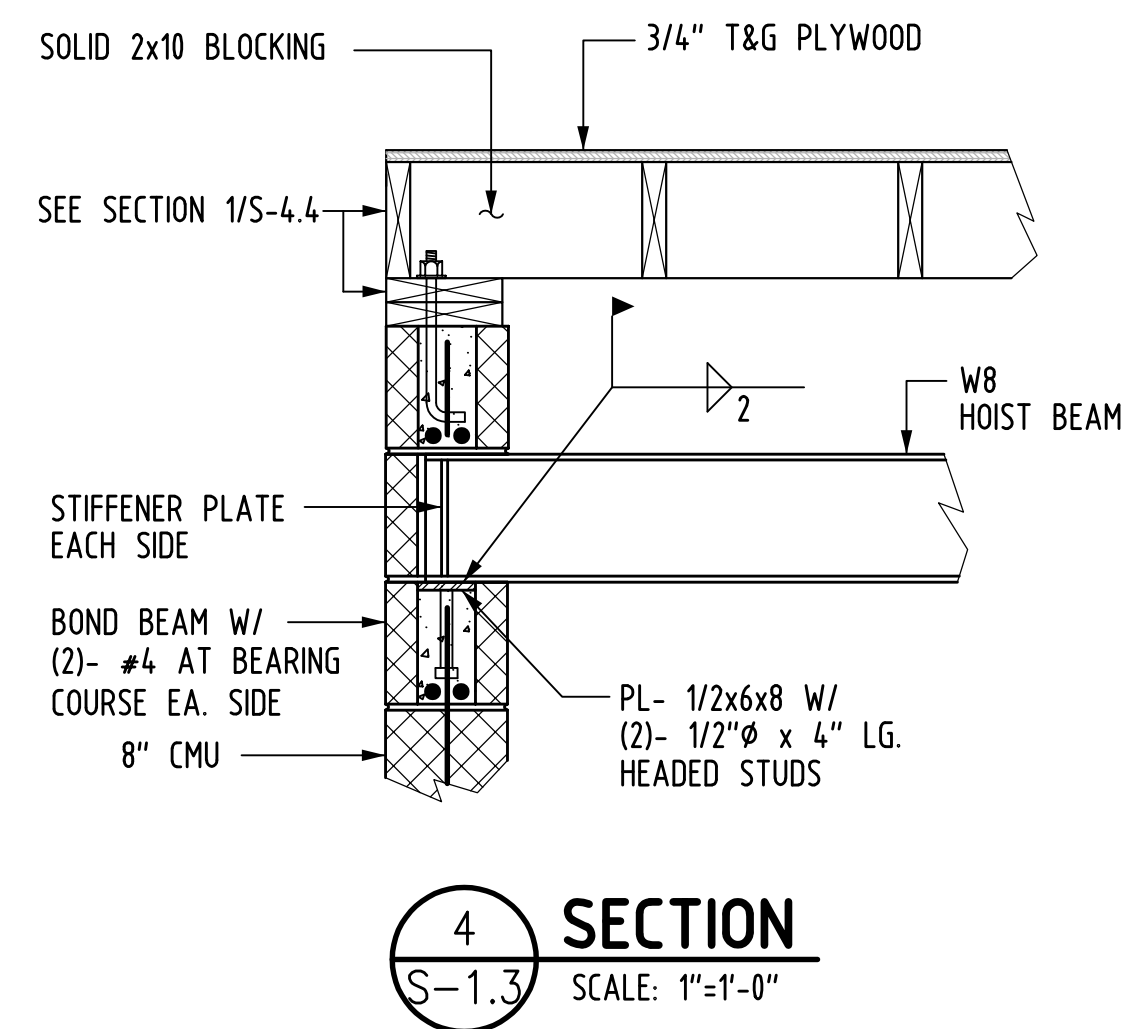
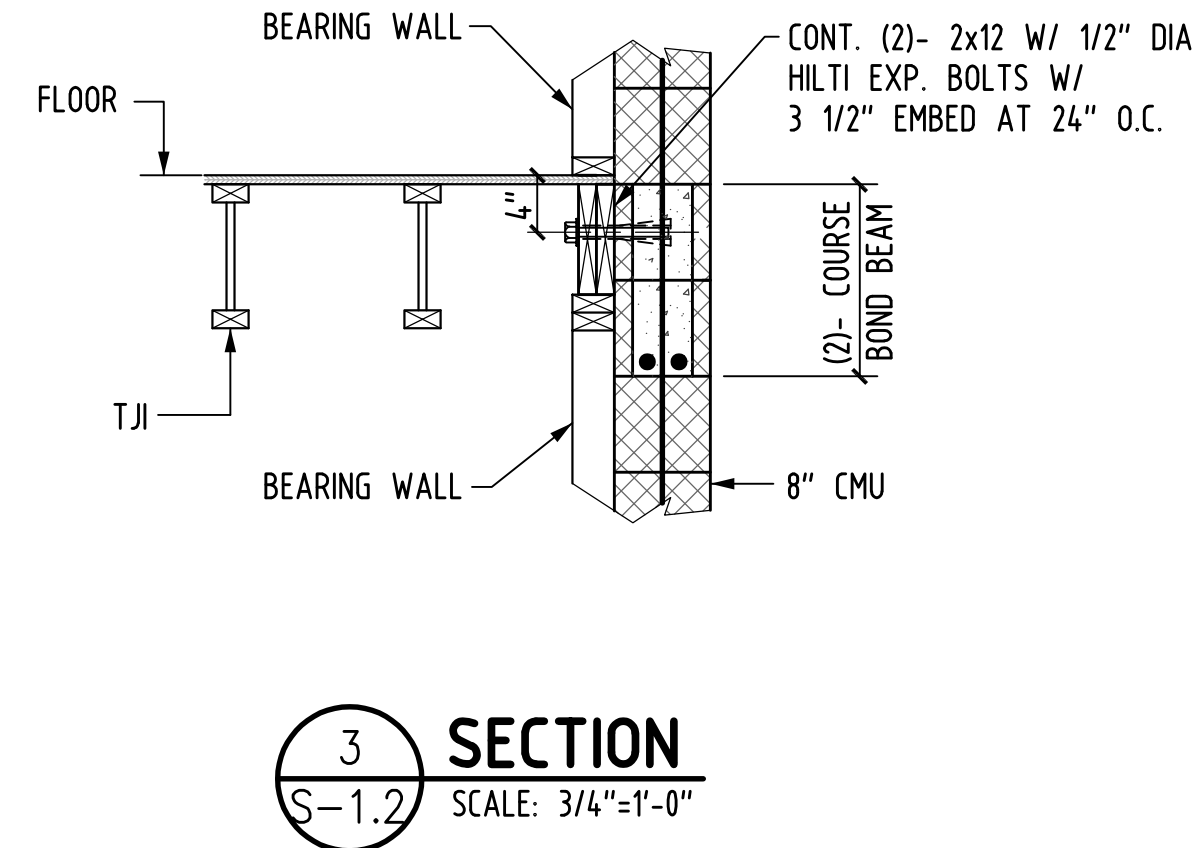
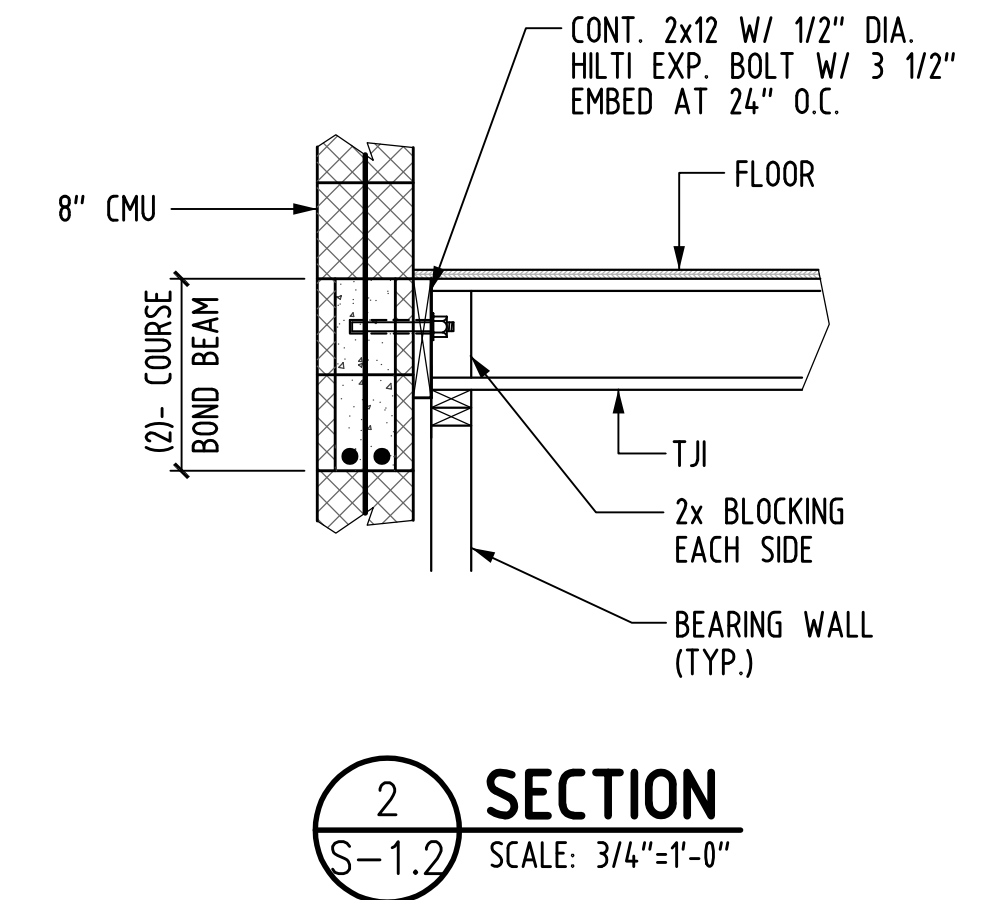
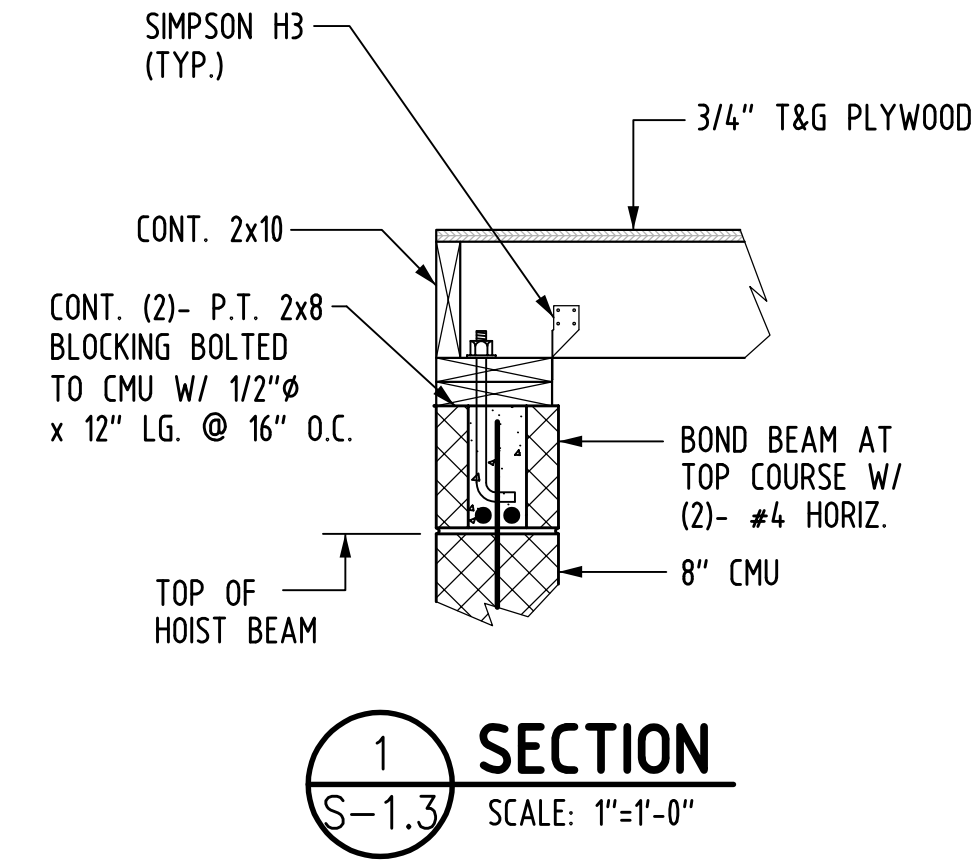
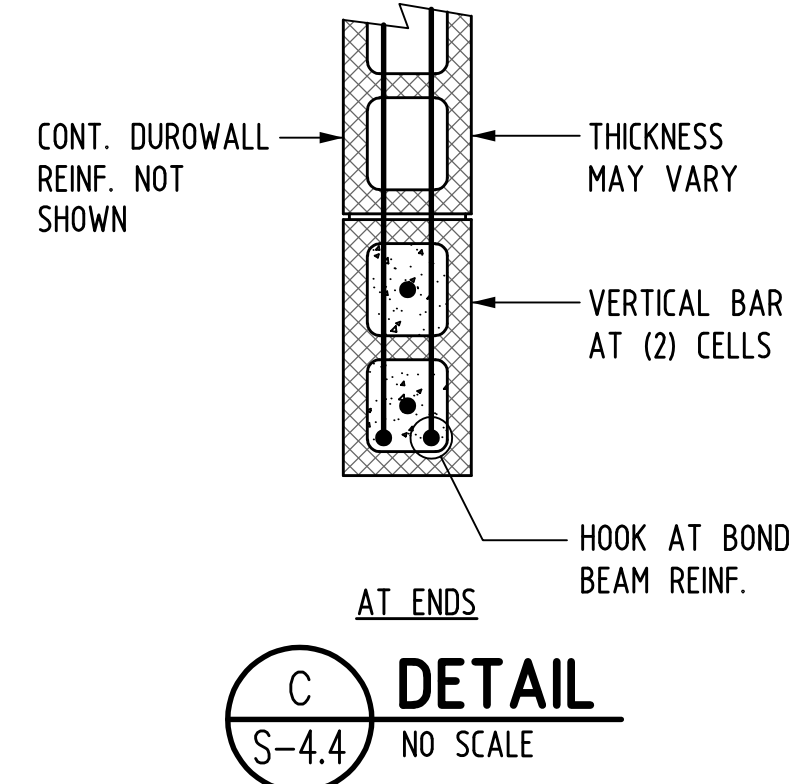
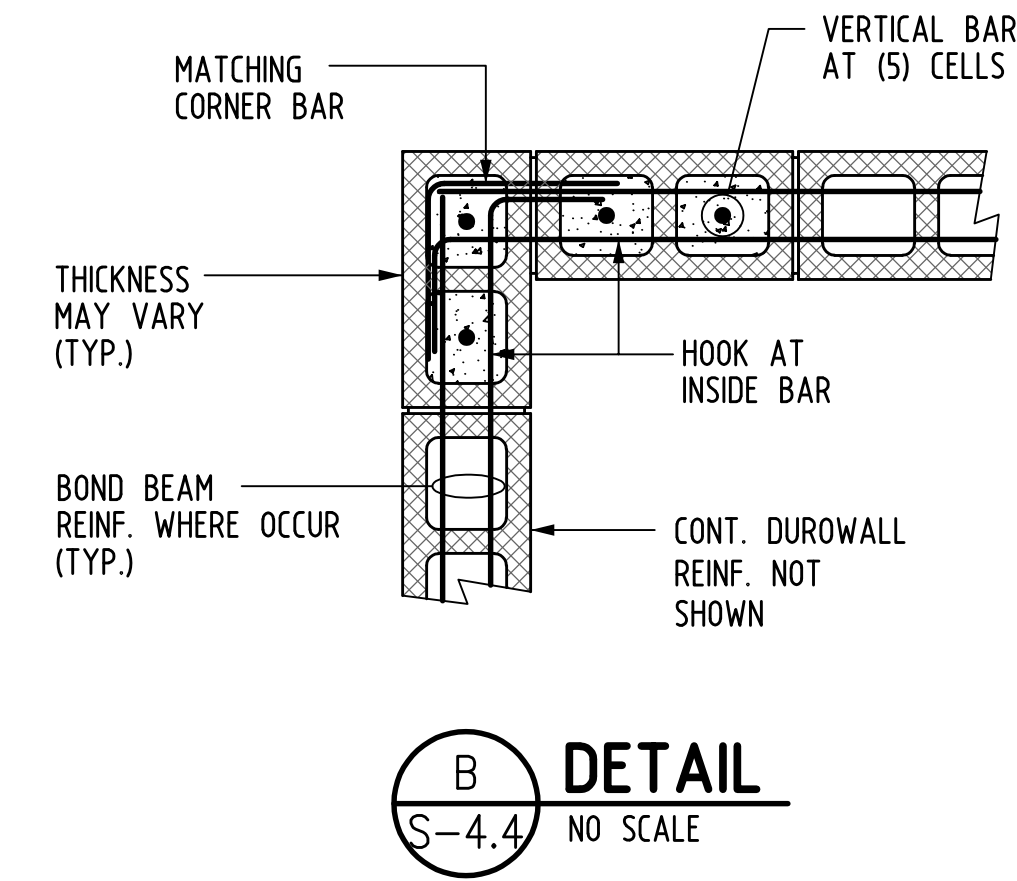
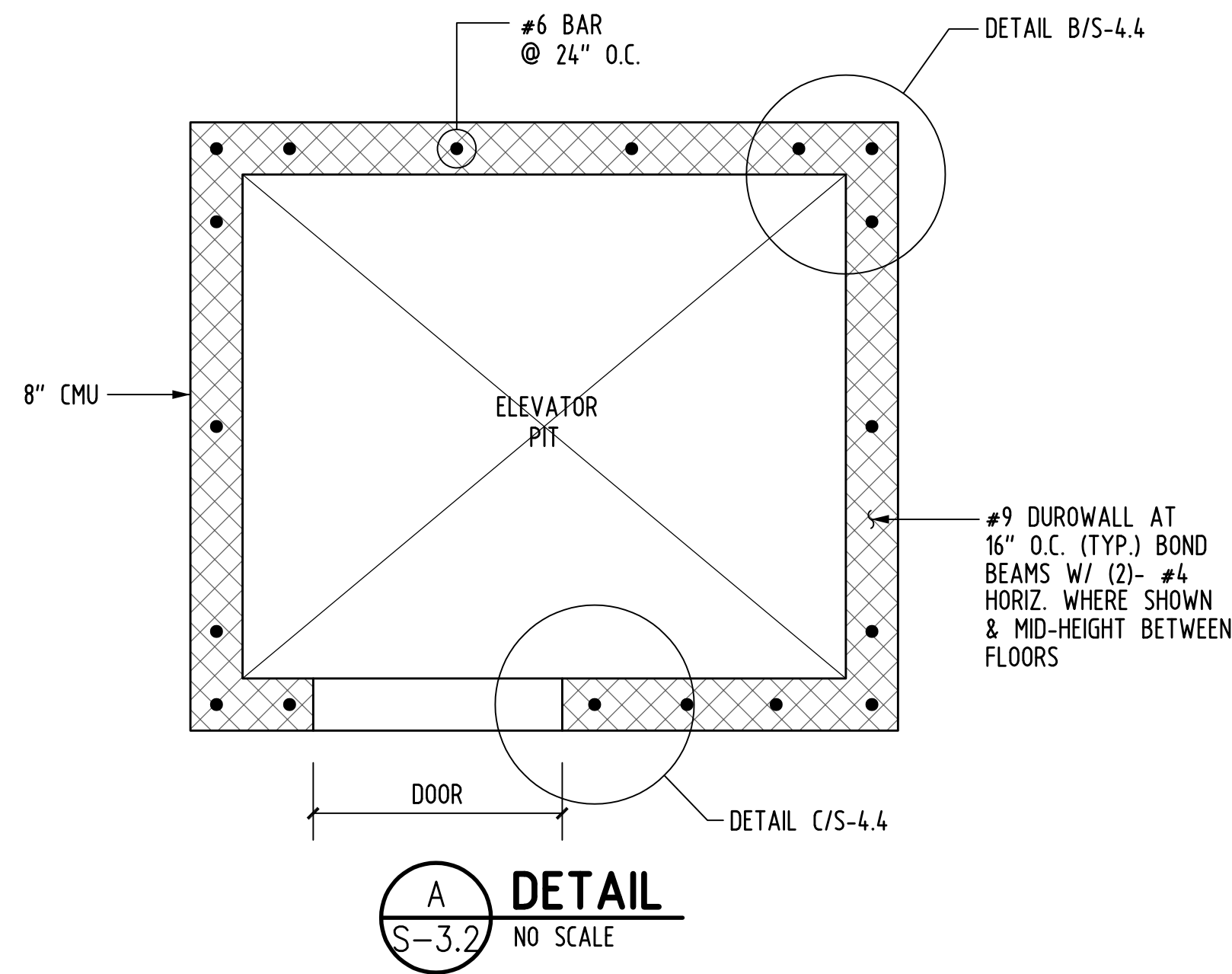

**Wentworth Hall
Library
Expansion
918
Washington Street
Islington, MA**

OWNER

architects
mckay

35 Bryant Street
Dedham, MA 02026
ph. 781.326.5400
www.mckayarchitects.net

GOLDSTEIN-MILANO LLC
Structural Engineers

125 Main Street
Reading, MA 01867
781-670-9990 (p)
781-670-9939 (f)

REV # DATE ISSUANCE

OWNERSHIP & USE OF DOCUMENTS

These drawings and specifications are the property and copyright of McKay Architects and shall not be used in whole or in part, or shall be assigned to a third party without the express written permission of McKay Architects.
Contractor to verify all information and dimensions in the field prior to start of construction and is to notify McKay Architects of any discrepancies

Wood Details IV

JOB NO
18197.00
DATE
05.29.19
DWG BY
DAD
CKD BY
BRG
SCALE
AS NOTED

S-4.4

